

BusPort™ INSTALLATION MANUAL Model #TR3



MECHANICAL INSTALLATION

CAUTION: Turn-off all power before performing any work on the wiring system.
Use only Listed or IEC rated wiring devices and accessories.

RATINGS:

Maximum voltage: 300 volts, 50/60 Hz

Wire using only #12 AWG or 2.5mm maximum, 90° C minimum

Use stranded wire only, 8 conductors maximum per conduit

Maximum amps per circuit:

20 (#12AWG) US & Canada, 16 (2.5mm) IEC

Maximum weight load: 2,500lbs. (1,134kg)

(Safety factor of 3)

Conforms to UL 1573, CSA/CAN C22.2

No. 166-M1983, EN60598-2-17/A2:1991

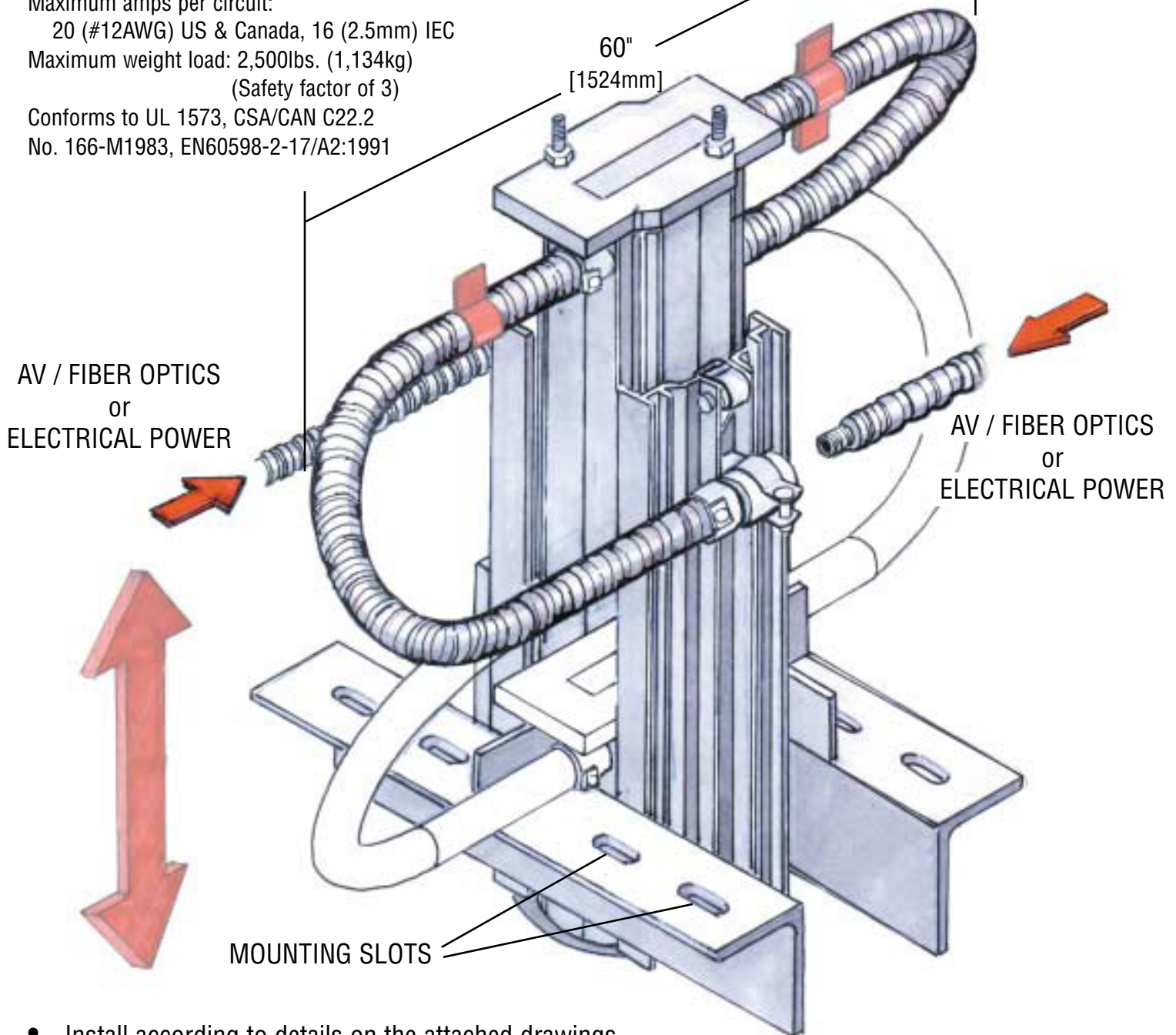

- Install according to details on the attached drawings.
- Attach to structure using all 8 slots, found on 2 mounting flanges, in a manner suitable to support the rated load both vertically and laterally.
- Use grade-5 hardware (ASTM F568 CLASS-8.8) (minimum rating). See bottom & mounting slots view shown on the installation drawing.
- Structure must be capable of supporting the full rated load.
- Allow 60" [1524mm] width clearance for moving parts and conduit.

ELECTRICAL INSTALLATION

CAUTION: Turn-off all power before performing any work on the wiring system.
Use only Listed or IEC rated wiring devices and accessories.

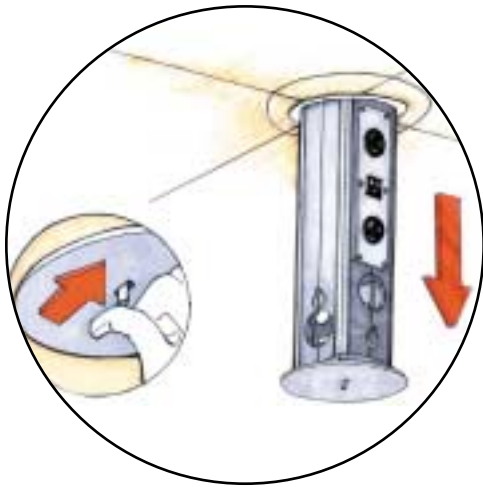

Step One –

To lower BusPort™ into useable position, move latch and lower unit carefully with manual support. Do Not stand directly under unit.

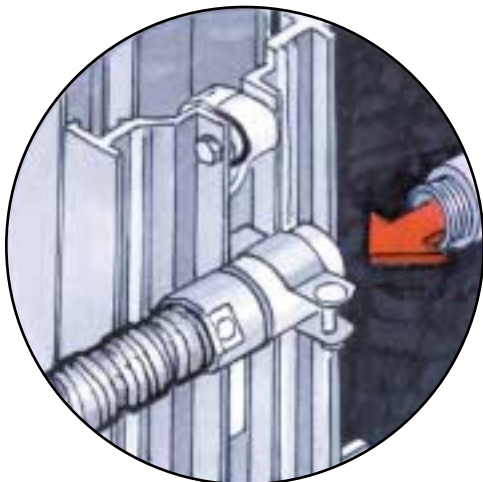

Step Two –

Bring power wires (or AV/communication) to unit in suitable flexible conduit, make sure the actual wires extend beyond the flexible conduit connector point at least 2.5 meters or 7.5 feet.

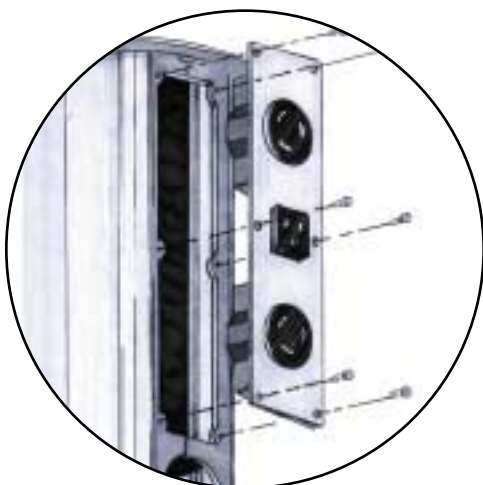

Step Four –

Wire all connections on BusPort™.

Questions? Call customer service at 1-800-238-4120.

RAISING & LOWERING UNIT

CAUTION: Turn-off all power before performing any work on the wiring system.
Use only Listed or IEC rated wiring devices and accessories.

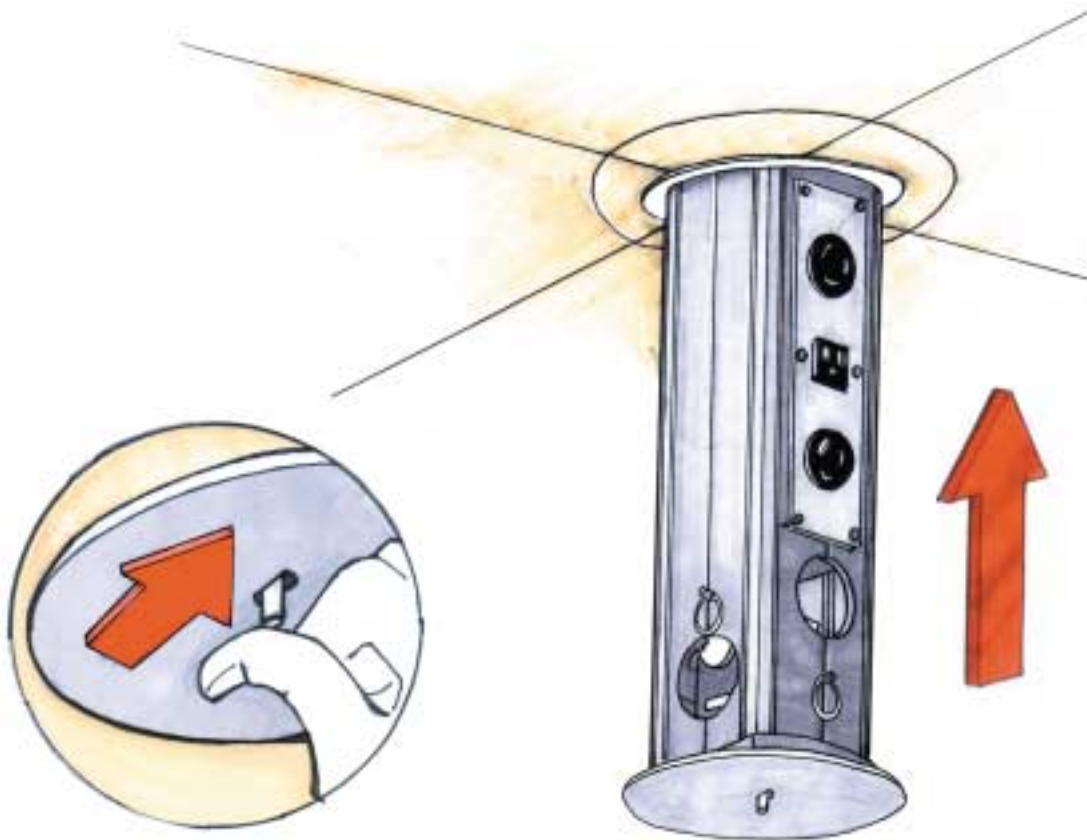

Step Five –

To raise unit, depress catch with latch and manually push unit up into storage position then release latch.

Pull down gently on coverplate to be sure the catch is engaged. Never stand directly under unit and always be sure nothing is placed into BusPort™ when retracting.

Questions? Call customer service at 1-800-238-4120.

