

BUS-44R

Recessed (Concrete)

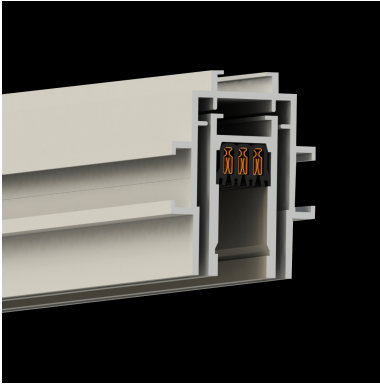

Project Name

Type

<input type="text"/>	<input type="text" value="-44R"/>	<input type="text"/>	<input type="text" value="XX"/>	<input type="text"/>	<input type="text"/>	<input type="text"/>	<input type="text"/>
----------------------	-----------------------------------	----------------------	---------------------------------	----------------------	----------------------	----------------------	----------------------

Feed Code	Profile / Mounting	Vinyl / Voltage	Vinyl / Voltage	Amperage	Total Length of Straight Run (in.)*	Finish	Whip (ft.)
BUS	<input type="text" value="CEC"/>	1A	N/A	16A	<input type="text" value="1A"/>	White	P
CCF	<input type="text" value="EEC"/>	2A		20A	1.5A	Matte Black	MB
CEF	<input type="text" value="SEC"/>	6A	(Provided)	30A	2A	Brushed	BR
EEB	<input type="text" value="TEC"/>	3D		60A	3A	Unfinished	UF
EEF		2D			4A	Custom	CP
SEF		6D			5A	<input type="text"/>	
TCB		3C			6A		
TCF					8A		
TEB					12A		
TEF							

Finish Code

Circuiting Chart

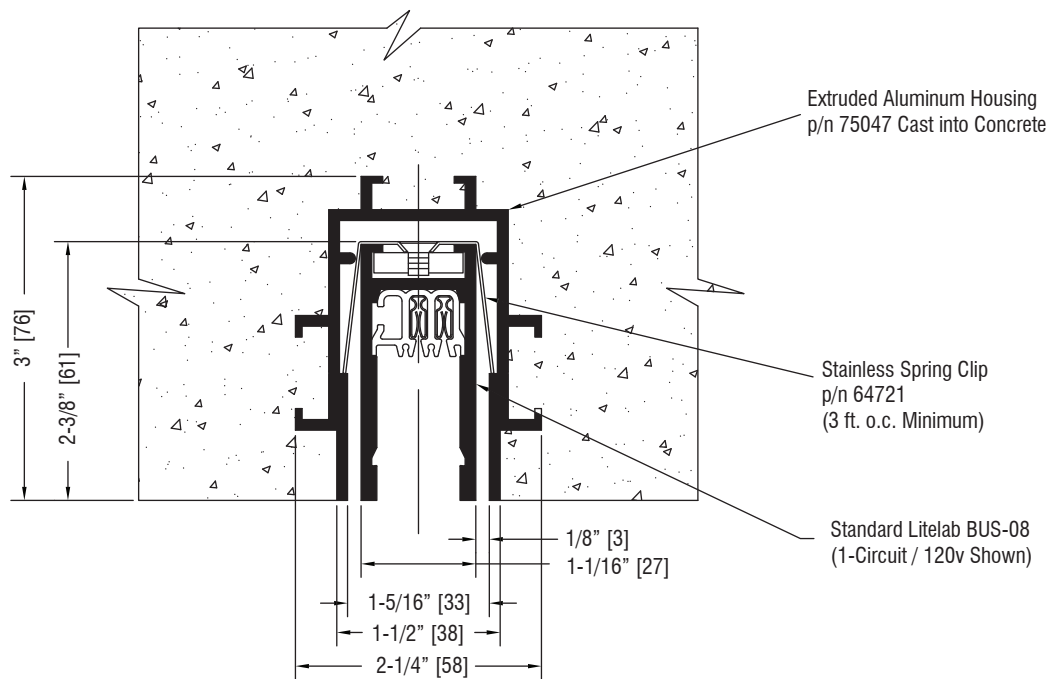
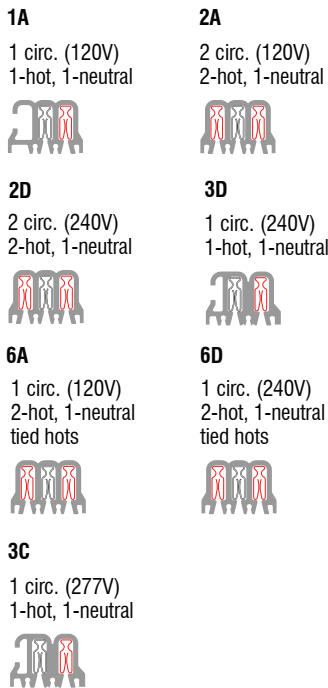

Feed Options: Standard BusRun feed capacity is 20 Amps (120v) or 16 Amps (230 Volt); 30 and 60 Amp feeds are available

TEF-44R
TEC-44R (Current Limiter)*
Top End Feed
1/2" NPSM or 20mm Conduit

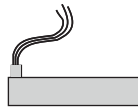

TCF-44R
Top Center Feed
1/2" NPSM or 20mm Conduit

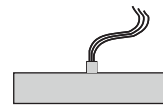

EEF-44R
EEC-44R (Current Limiter)*
End End Feed
1/2" NPSM or 20mm Conduit

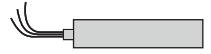

TEB-44R
Top End Splice-Box
30 Amp Max

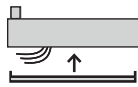

TCB-44R
Top Center Splice Box
30 Amp Max

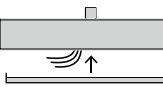

EEB-44R
End End Splice-Box
30 Amp Max



SEF-44R
SEC-44R (Current Limiter)*
Side End Feed
1/2" NPSM or 20mm Conduit



***CL: Current Limiter Values (120v Only)**

1A	120VA	5A	600VA
1.5A	180VA	6A	720VA
2A	240VA	8A	960VA
3A	360VA	12A	1440VA
4A	480VA		

BUS-44R

Recessed (Concrete)

Project Name

Type

Mounting Diagram

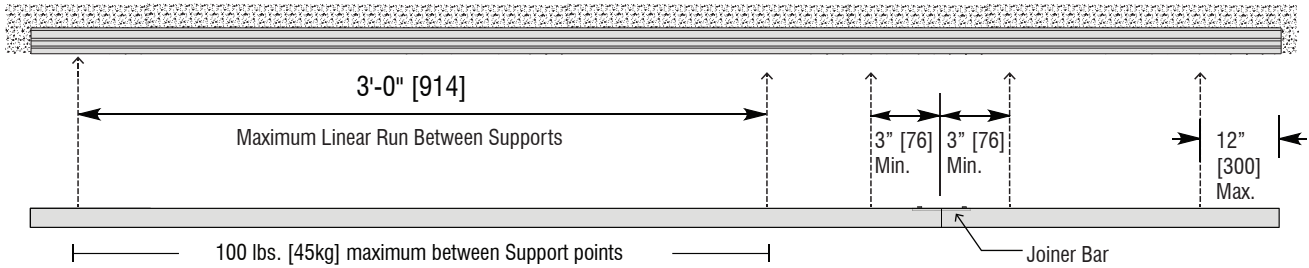

Dimension Chart

Top End Feed

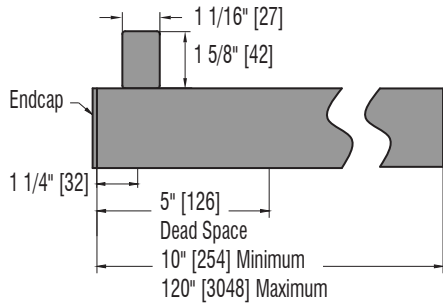

Top End Splice-Box Feed

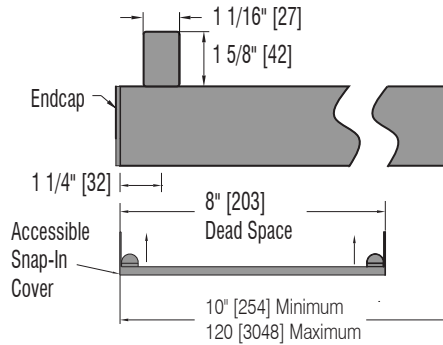

End End Feed

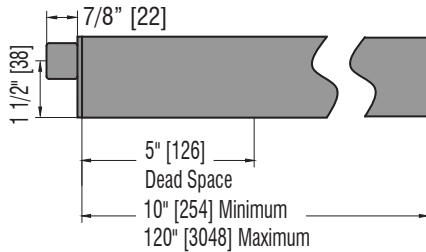

End End Splice-Box Feed

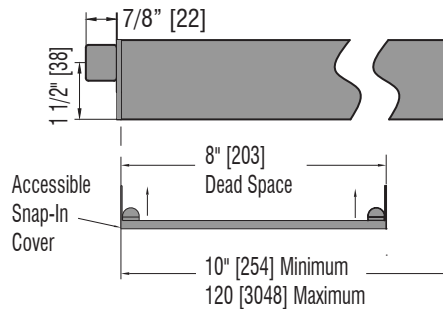

Top Center Feed

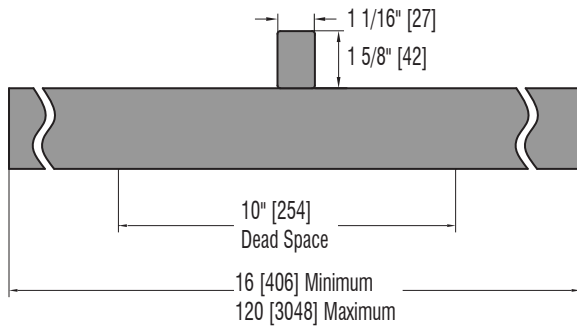

Top Center Splice-Box Feed

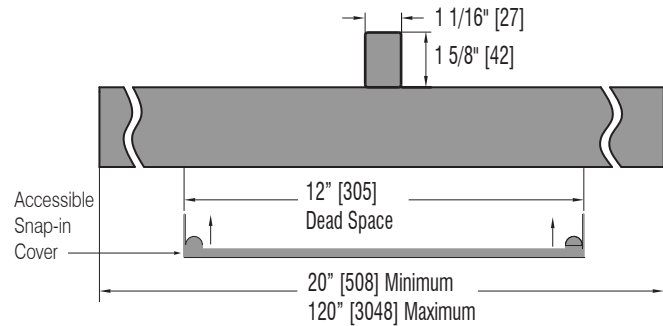

BUS-44R

X, T, L Configurations

Project Name

Type

L-Dimensions (Typical):

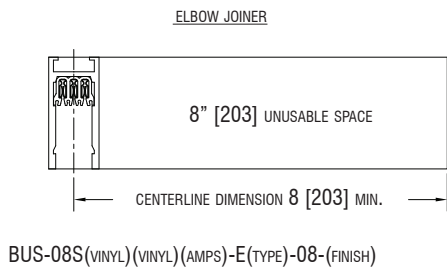
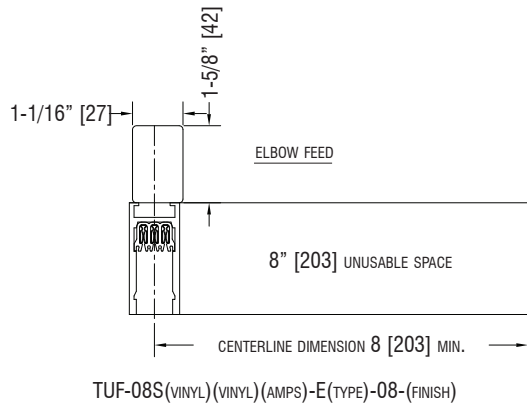
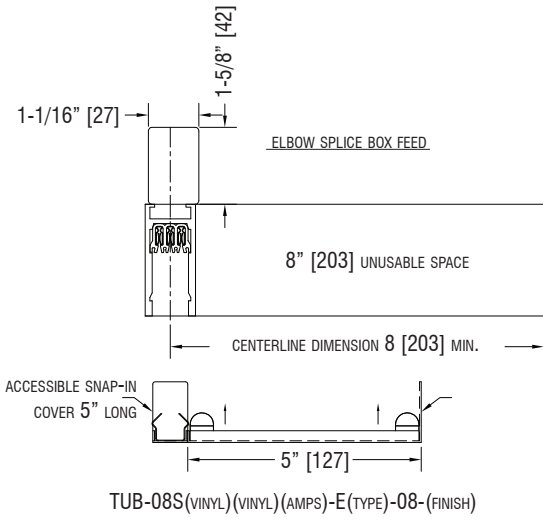

MAXIMUM UNIT LENGTH IS 10' [3048] UNINTERRUPTED SPAN. SPLICE KITS TO ADJACENT SECTIONS OCCUPY 4" [102] FOR 16, 20 AND 30 AMP CAPACITY AND 6" FOR 60 AMP CAPACITY. WHEN CALCULATING PLUG-IN SPACE:

$$(TOTAL LENGTH OF SECTION) - (FEED) - (SPLICE KIT/2) = TOTAL AVAILABLE PLUG-IN SPACE$$

FOR FITTER LENGTHS, PLEASE SEE FIXTURE CUTSHEETS.

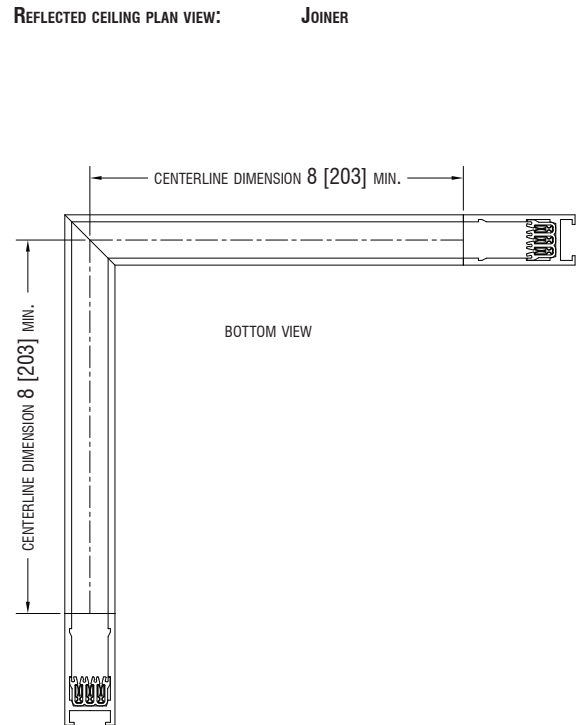
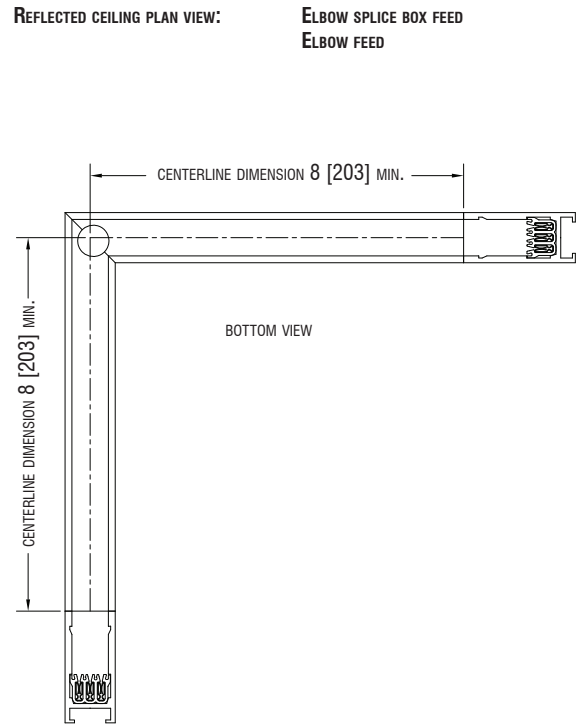

BUS-44R

X, T, L Configurations

Project Name

Type

T-Dimensions (Typical):

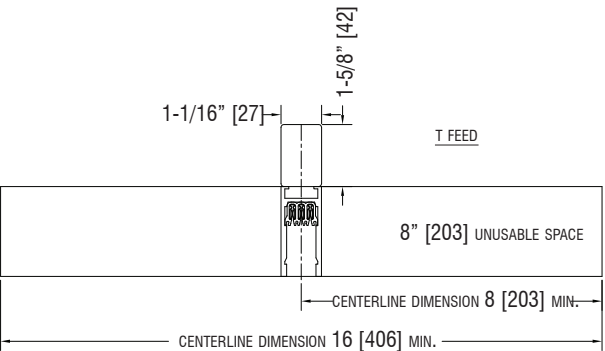
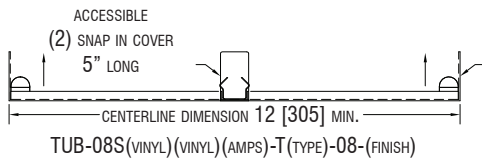
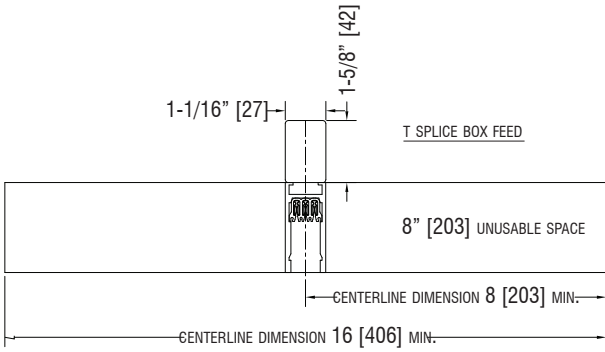

TUF-08S(VINYL)(VINYL)(AMPS)-T(TYPE)-08-(FINISH)

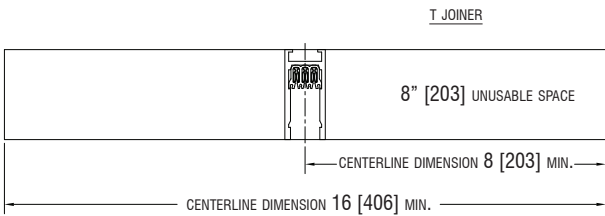

TUF-08S(VINYL)(VINYL)(AMPS)-T(TYPE)-08-(FINISH)

MAXIMUM UNIT LENGTH IS 10' [3048] UNINTERRUPTED SPAN. SPLICE KITS TO ADJACENT SECTIONS OCCUPY 4" [102] FOR 16, 20 AND 30 AMP CAPACITY AND 6" FOR 60 AMP CAPACITY. WHEN CALCULATING PLUG-IN SPACE:

$$(TOTAL LENGTH OF SECTION) - (FEED) - (SPLICE KIT/2) = TOTAL AVAILABLE PLUG-IN SPACE$$

FOR FITTER LENGTHS, PLEASE SEE FIXTURE CUTSHEETS.

REFLECTED CEILING PLAN VIEW:

ELBOW SPLICE BOX FEED
ELBOW FEED

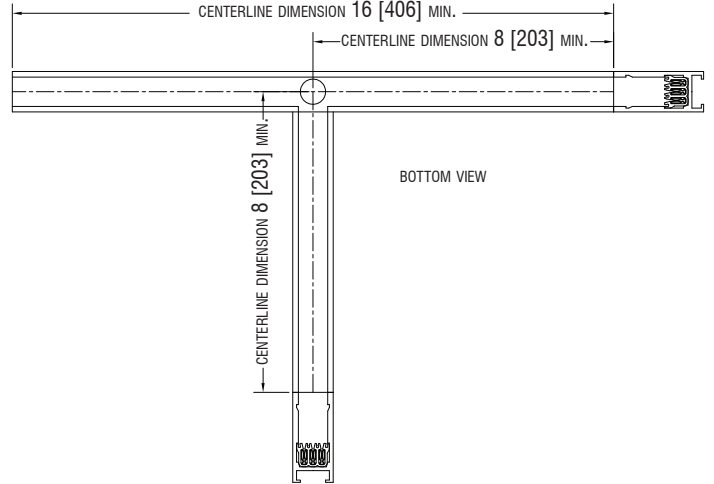

REFLECTED CEILING PLAN VIEW:

JOINER

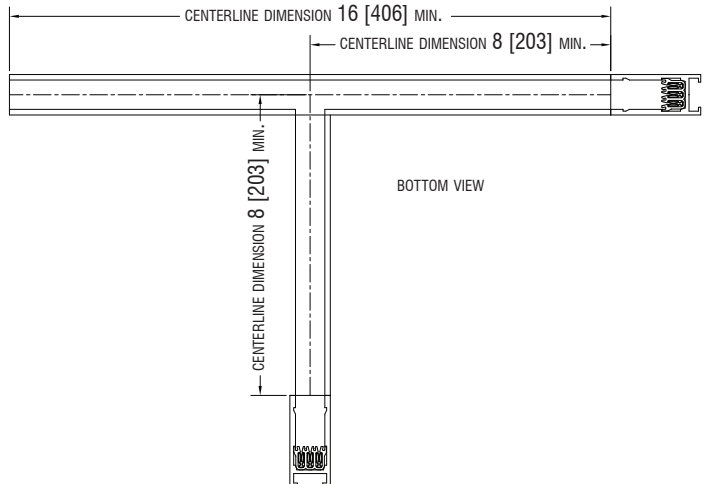

BUS-44R

X, T, L Configurations

Project Name

Type

X-Dimensions (Typical):

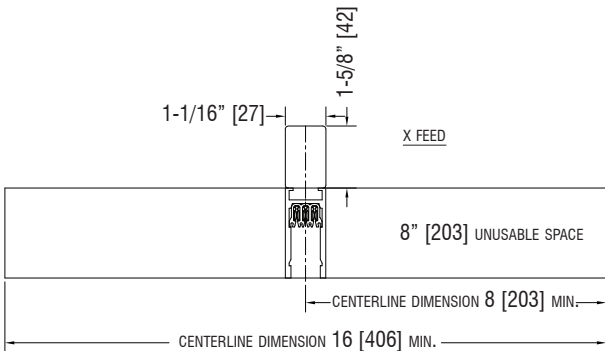
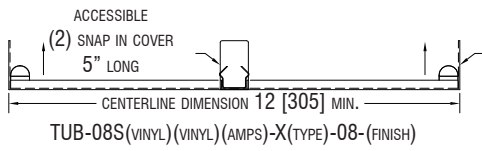
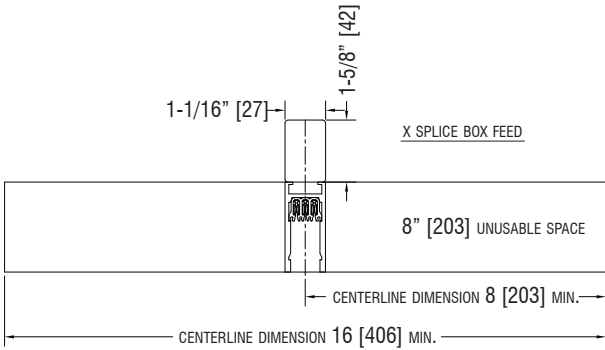

TUF-08S(VINYL)(VINYL)(AMPS)-X(TYPE)-08-(FINISH)

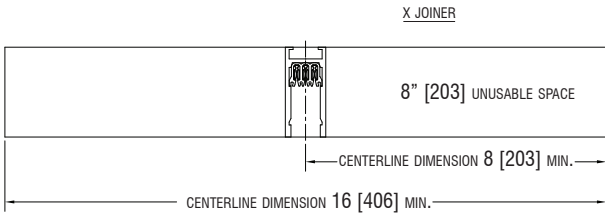

TUF-08S(VINYL)(VINYL)(AMPS)-X(TYPE)-08-(FINISH)

MAXIMUM UNIT LENGTH IS 10' [3048] UNINTERRUPTED SPAN. SPLICE KITS TO ADJACENT SECTIONS OCCUPY 4" [102] FOR 16, 20 AND 30 AMP CAPACITY AND 6" FOR 60 AMP CAPACITY. WHEN CALCULATING PLUG-IN SPACE:

$$(TOTAL LENGTH OF SECTION) - (FEED) - (SPLICE KIT/2) = TOTAL AVAILABLE PLUG-IN SPACE$$

FOR FITTER LENGTHS, PLEASE SEE FIXTURE CUTSHEETS.

REFLECTED CEILING PLAN VIEW:

ELBOW SPLICE BOX FEED
ELBOW FEED

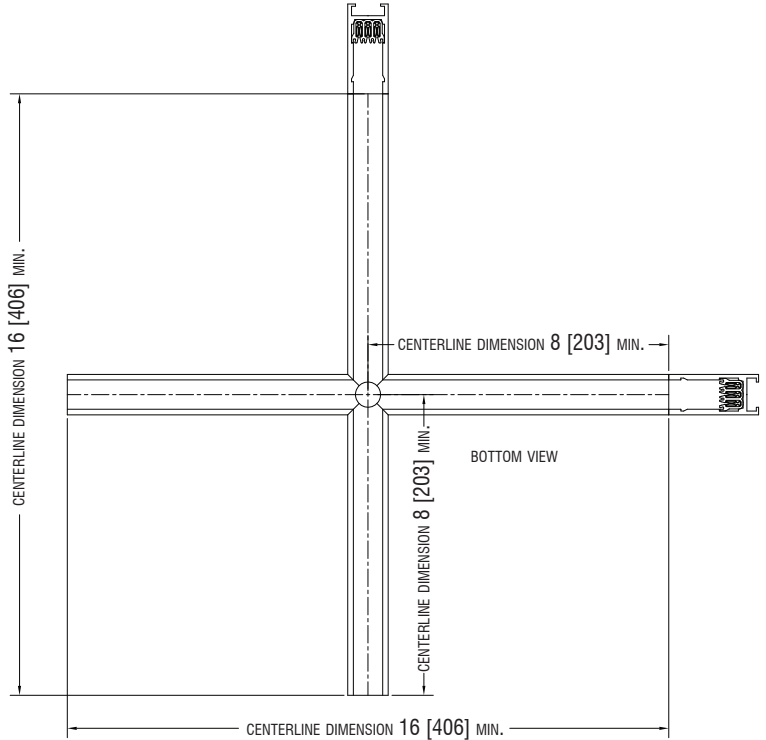

REFLECTED CEILING PLAN VIEW:

JOINER

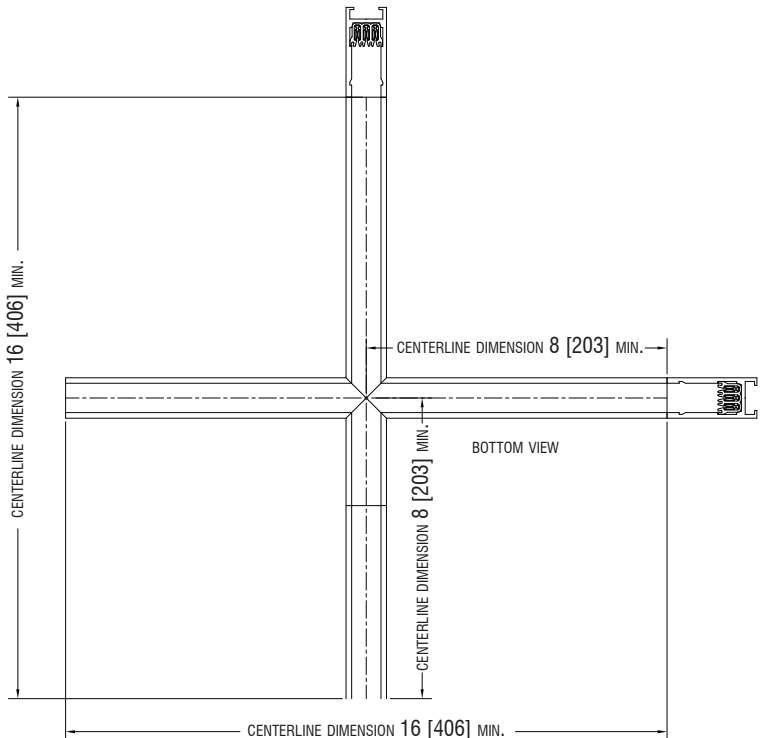

BUS-44R

Accessories

Project Name

Type

BusBridge

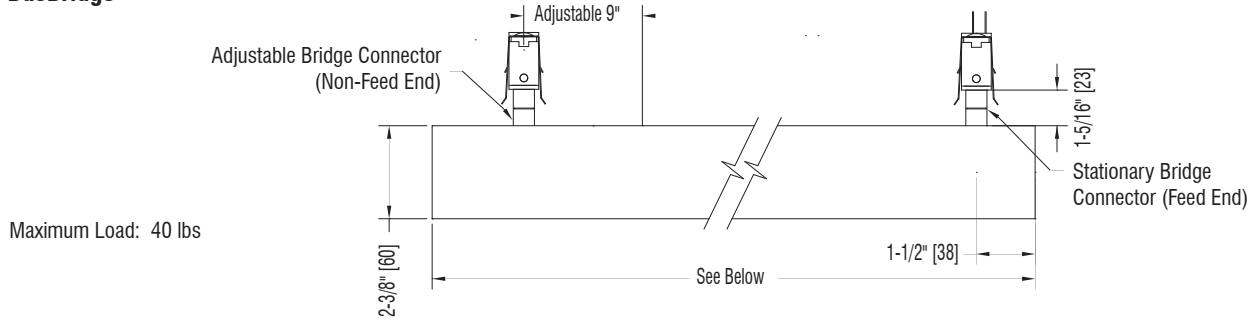

Maximum Load: 40 lbs

Codes	Adaptor/Voltage	Finish
BB1D-054 3'9" [Min. Span] 4'3" [Max. Span] 4'6" [Total Length]	9AD-A (120 Volts)	P=White
BB1D-102 7'9" [Min. Span] 8'3" [Max. Span] 8'6" [Total Length]	9AD-D (240 Volts)	MB = Matte Black
BB1D-120 9'0" [Min. Span] 9'9" [Max. Span] 10'0" [Total Length]	9AD-C (277 Volts)	NT = Brushed
		UF = Unfinished
		ST = Silver Tone

Example: BB1D-102-9AD-A-MB

Sign Hanger*

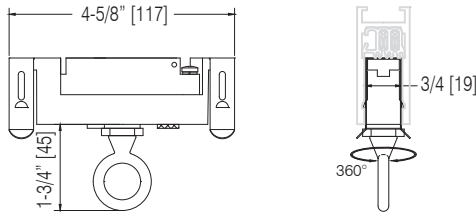

Supports 40lb (18kg) Maximum Static Vertical Load

Code	Adaptor	Finish
BSH	9ED	P=White
		MB = Matte Black
		ST = Silver Tone
		R = Unfinished

Loadmatic Hanging

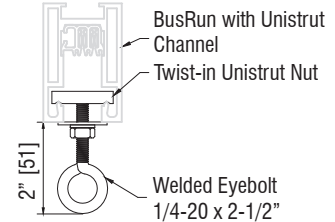

Supports up to 100lb [45kg] Maximum Static Vertical Load

Code	Finish
BSH-UNI	P=White
	MB = Matte Black
	R = Unfinished

PowerDown Box*

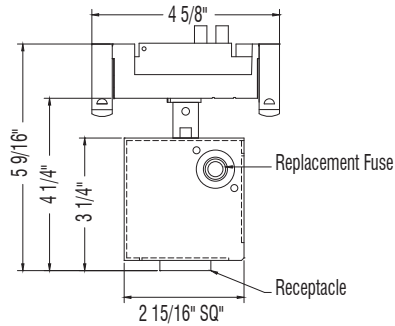

Code/Amperage	Adaptor / Voltage	Finish
3-Prong Edison Plug		P=White
BPT-P15F	9AD-A (120 Volts)	MB=Matte Black
Twist Lock		ST=Silver Tone
BPT-T15F	9AD-A (120 Volts)	CP=Custom Finish
BPT-T20F		

NEMA Guide	120 volt	277 volt
BPT-P15F	5-15R	
BPT-T15F	L5-15R	L7-15R
BPT-T20F	L5-20R	L7-20R

PowerDown Breaker*

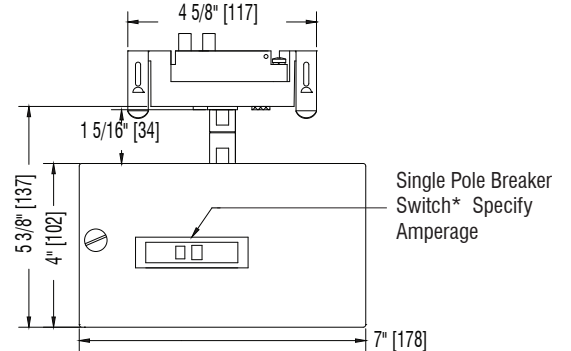

Code/Amperage	Adaptor / Voltage	Finish
BPT-K15B	9AD (120 Volts)	P=White
BPT-K20B		MB=Matte Black
BPT-K30B		ST=Silver Tone
		CP=Custom Finish

Includes knockouts

* Includes 11" Safety Cable



251 Elm Street, Buffalo, NY 14203 USA
800-238-4120 | www.litelab.com

