

BUS-14R

Recessed D-Bar, Trimmed



Project Name

Type

 -14R XX

Feed Code	Profile / Mounting	Vinyl / Voltage	Vinyl / Voltage	Amperage	Total Length of Straight Run (in.)*	Finish	Whip (ft.)
BUS	CEC	1A	n/a	16A	1A	White	P
EEB	SEC	2A		20A	1.5A	Matte Black	MB
EEF	TEC	6A		30A	2A	Brushed	NT
SCB		3D		60A	3A	Unfinished	UF
SCF		2D			4A	Custom	CP
SEB		6D			5A		
SEF		3C			6A		
TCB		4B			8A		
TCF		4K			12A		
TEB							
TEF							

Circuiting Chart

1A 1 circ. (120V) 1-hot, 1-neutral 	2A 2 circ. (120V) 2-hot, 1-neutral 	3D 1 circ. (230V) 1-hot, 1-neutral
2D 2 circ. (240V) 2-hot, 1-neutral 	3C 1 circ. (277V) 1-hot, 1-neutral 	4B (Consult Factory) 1 circ. (Low Voltage) 1-hot, 1-neutral
4K (Consult Factory) 1 circ. (Low Voltage) International 1-hot, 1-neutral 	6A 1 circ. (120V) 2-hot, 1-neutral tied hots 	6D 1 circ. (230V) 2-hot, 1-neutral tied hots

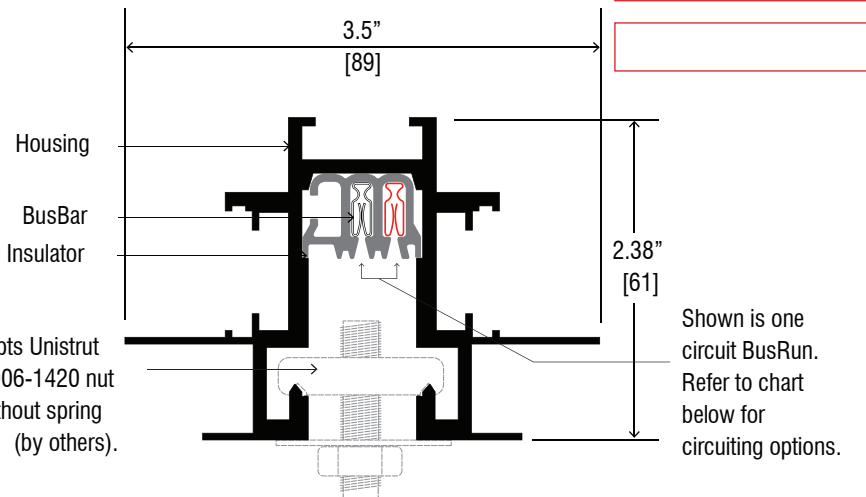

Shown is one circuit BusRun. Refer to chart below for circuiting options.

Feed Options: Standard BusRun feed capacity is 20 Amps (120v) or 16 Amps (230 Volt); 30 and 60 Amp feeds are available

TEF-14R TEC-14R ((Current Limiter)*) Top End Feed 1/2" NPSM or 20mm Conduit 	TCF-14R Top Center Feed 1/2" NPSM or 20mm Conduit 	SEF-14R SEC-14R (Current Limiter)* Side End Feed 1/2" NPSM or 20mm Conduit
TEB-14R Top End Splice-Box 30 Amp Max 	TCB-14R Top Center Splice Box 30 Amp Max 	SEB-14R Side End Splice Box 30 Amp Max
EEF-14R EEC-14R ((Current Limiter)*) End End Feed 1/2" NPSM or 20mm Conduit 	EEB-14R End End Splice-Box 30 Amp Max 	SCF-14R Side Center Feed 1/2" NPSM or 20mm Conduit

Notes:

1. All Splice Box feeds are 30 Amp maximum load.
2. All feeds are supplied with two end caps.
3. Feeds cannot be field modified.
4. Feeds can be made between 10" - 120".
5. Maximum loads are per circuit.

*CL: Current Limiter Values (120v Only)			
1A	120VA	5A	600VA
1.5A	180VA	6A	720VA
2A	240VA	8A	960VA
3A	360VA	12A	1440VA
4A	480VA		

SCB-14R
 Side Center Splice Box
 30 Amp Max



251 Elm Street, Buffalo, NY 14203 USA
 800-238-4120 | www.litelab.com



BUS-14R

Recessed D-Bar, Trimmed

Project Name

Type

Dimension Chart

Top End Feed

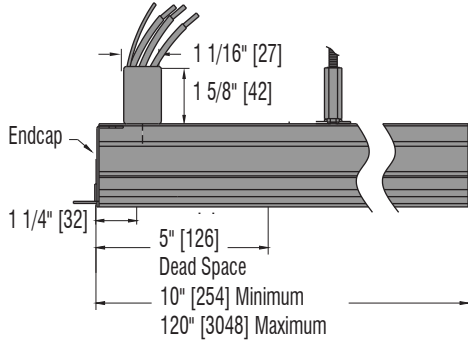

Top End Splice-Box Feed

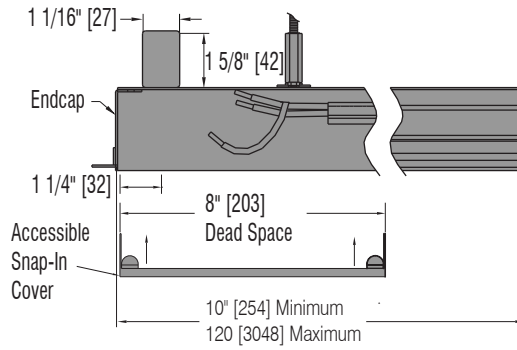

End End Feed

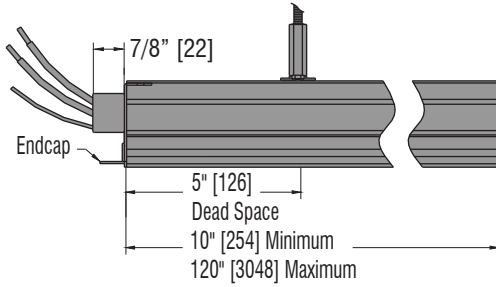

End End Splice-Box Feed

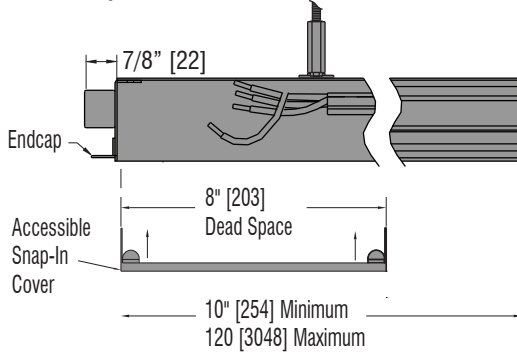

Side End Feed

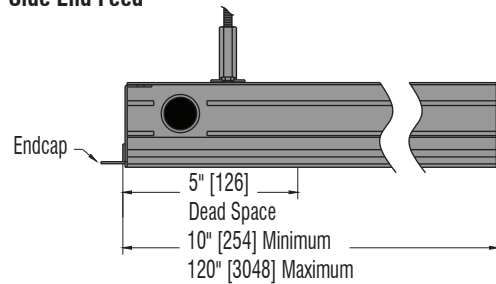

Side End Splice-Box Feed

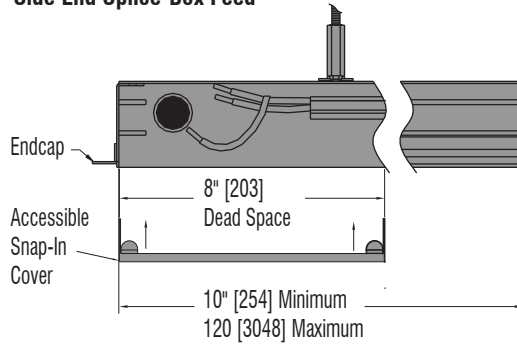

Top Center Feed

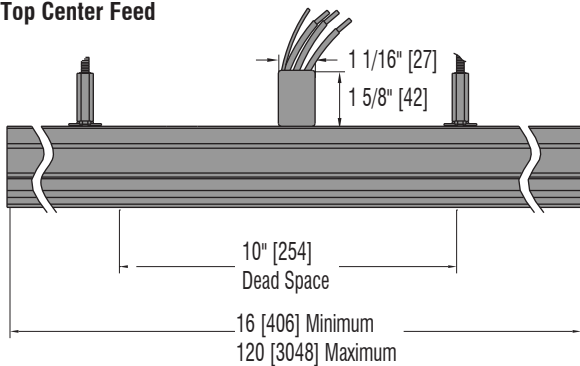

Top Center Splice-Box Feed

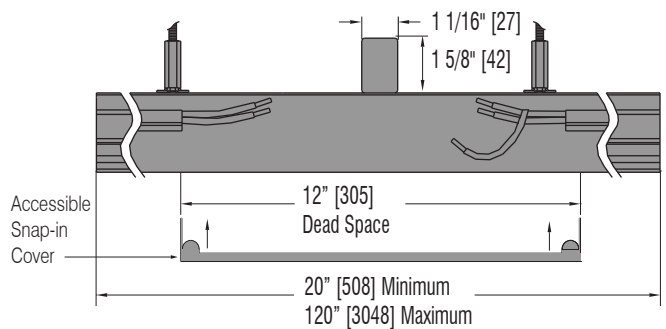

BUS-14R

Recessed D-Bar, Trimmed

Project Name

Type

Mounting Diagram

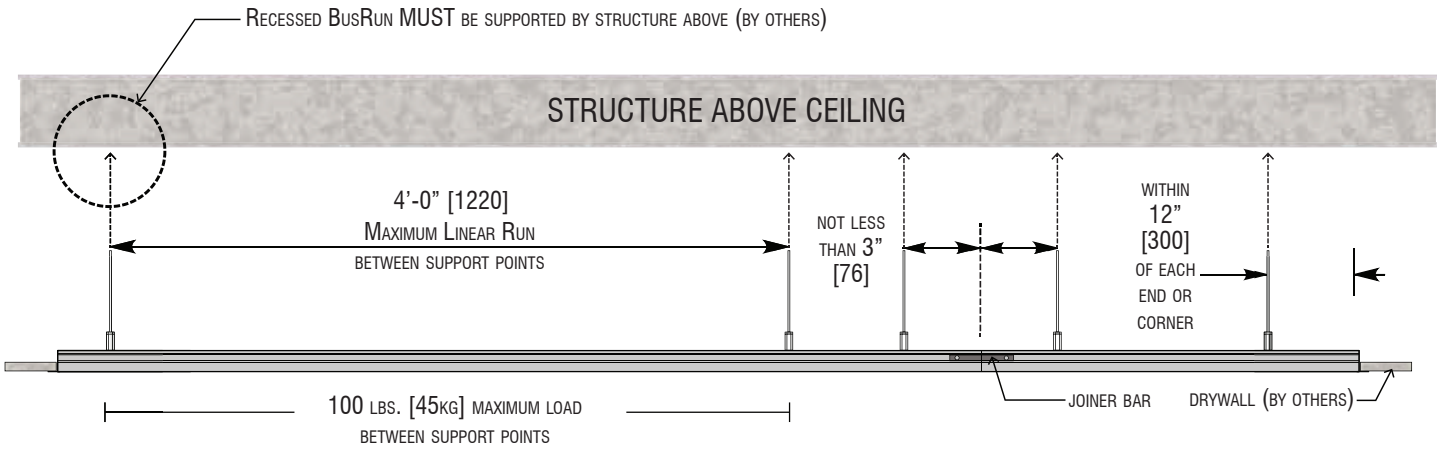

MOUNTING NOTES:

- 10'0" [3048] RECESSED BUSRUN SECTION REQUIRES 3 SUPPORT POINTS.
- 8'0" [2438] RECESSED BUSRUN SECTION REQUIRES 3 SUPPORT POINTS.
- 4'0" [1219] RECESSED BUSRUN SECTION REQUIRES 2 SUPPORT POINTS.

MOUNTING RULES

- 12" [300]** A SUPPORT POINT MUST BE PROVIDED WITHIN 12" OF EVERY END CORNER OF THE BUSRUN LAYOUT.
- 4'-0" [1220]** MAXIMUM DISTANCE BETWEEN SUPPORT POINTS CANNOT EXCEED 4'0" LINEAR FEET OF BUSRUN.
- 3" [76]** SUPPORT POINTS CANNOT BE WITHIN 3" FROM THE CENTERLINE ON BOTH SIDES OF BUSRUN JOINTS.
- 100LB [45KG]** BUSRUN BUSWAY AND MOUNTING HARDWARE ARE RATED FOR A TOTAL SUPPORTED WEIGHT UP TO 100 LBS [45KG] BETWEEN SUPPORT POINTS.

MOUNTING OPTIONS

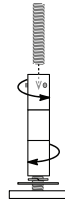

THREADED ROD HANGER

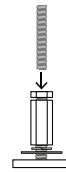

COUPLING NUT FOR THREADED ROD



RETAINING CLIP FOR CEILING SYSTEM

NICKEL-PLATED COUNTER-ROTATING THREADED ROD HANGER AND MOUNTING BAR ENABLE ATTACHMENT AND LEVELING OF BUSRUN TO FIXED THREADED ROD.

B-HHO-CK-M6-01 FOR M6 ROD

TBC-IT-01 (ORDERED SEPARATELY)

B-HHO-TR250 FOR 1/4-20 ROD

B-HHO-TR375 FOR 3/8-16 ROD

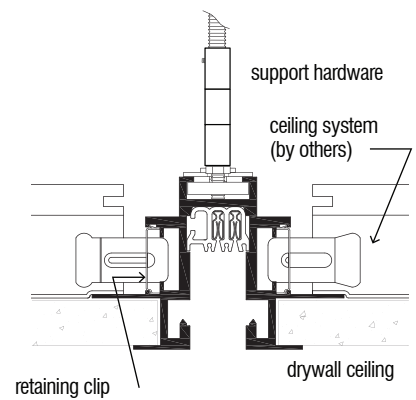
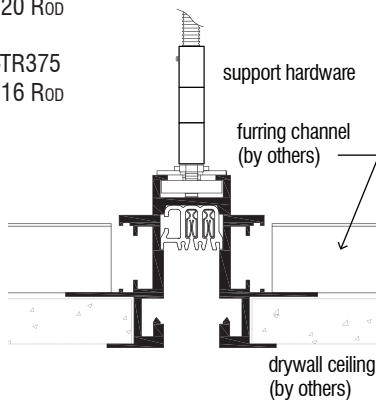

BUS-14R

X, T, L Configurations

Project Name

Type

L-Dimensions (Typical):

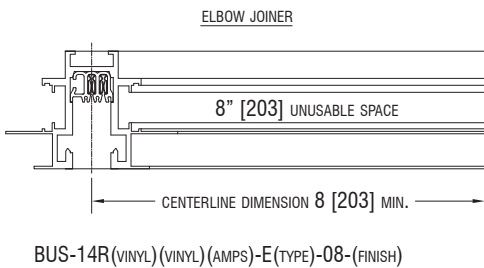
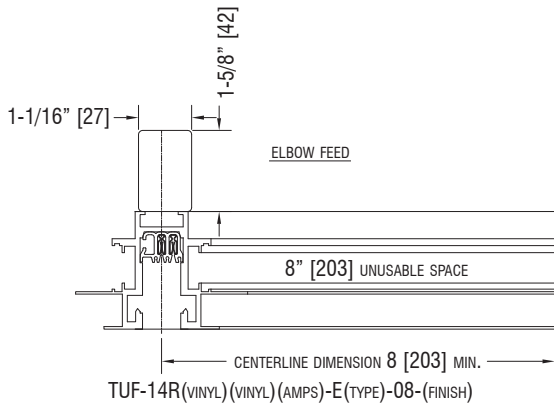
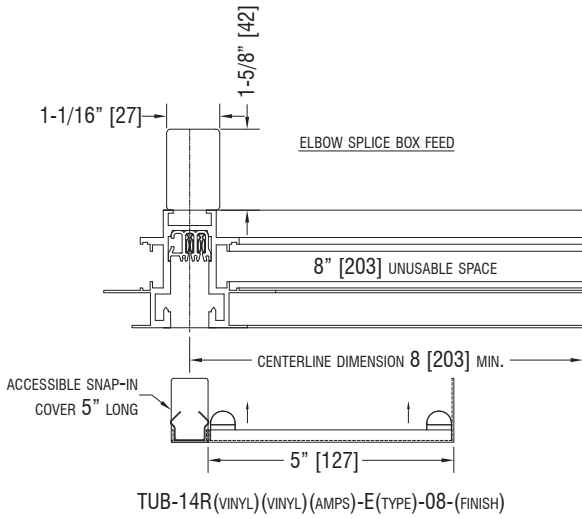

REFLECTED CEILING PLAN VIEW:

ELBOW SPLICE BOX FEED
ELBOW FEED

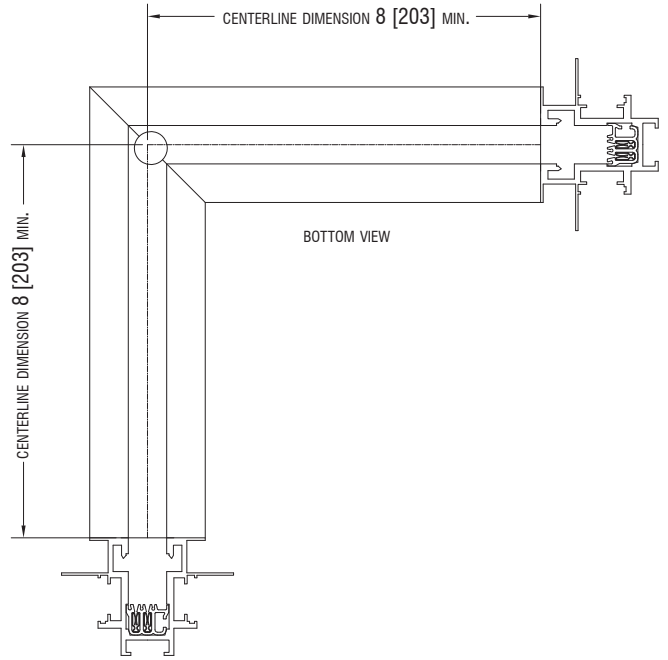

REFLECTED CEILING PLAN VIEW:

JOINER

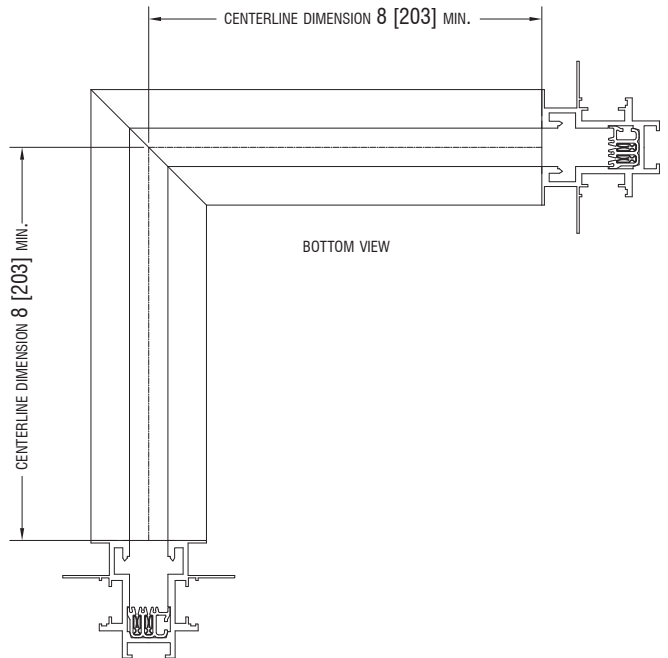

MAXIMUM UNIT LENGTH IS 10' [3048] UNINTERRUPTED SPAN. SPLICE KITS TO ADJACENT SECTIONS OCCUPY 4" [102] FOR 16, 20 AND 30 AMP CAPACITY AND 6" FOR 60 AMP CAPACITY. WHEN CALCULATING PLUG-IN SPACE:

$$(TOTAL LENGTH OF SECTION) - (FEED) - (SPLICE KIT/2) = TOTAL AVAILABLE PLUG-IN SPACE$$

FOR FITTER LENGTHS, PLEASE SEE FIXTURE CUTSHEETS.

BUS-14R

X, T, L Configurations

Project Name

Type

T-Dimensions (Typical):

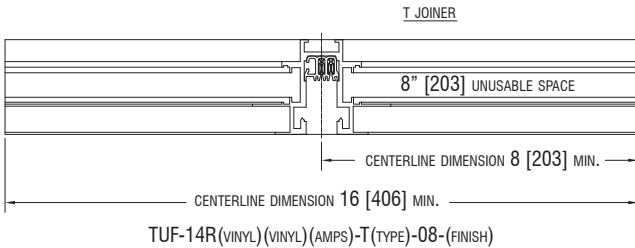
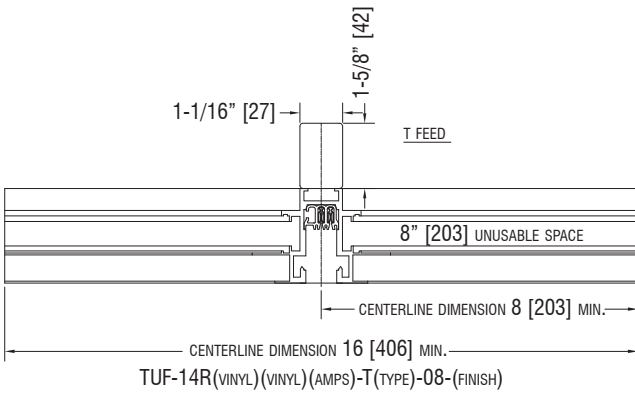
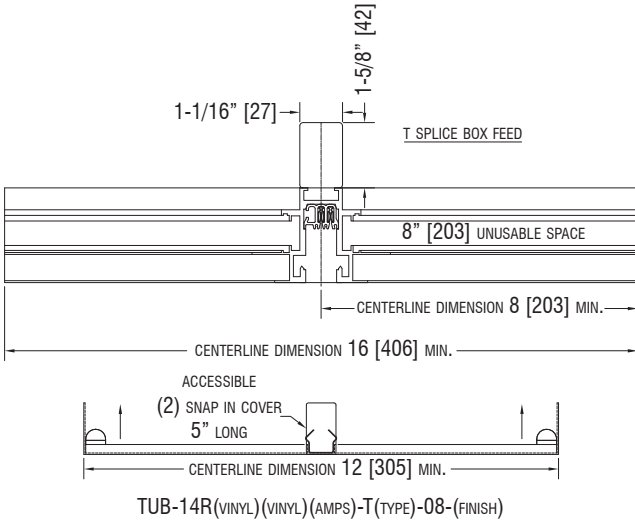

REFLECTED CEILING PLAN VIEW:

ELBOW SPLICE BOX FEED ELBOW FEED

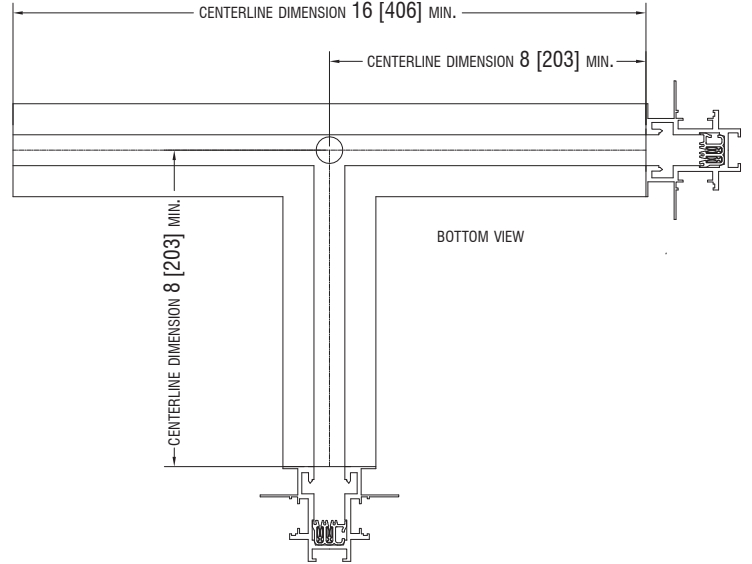

REFLECTED CEILING PLAN VIEW:

JOINER

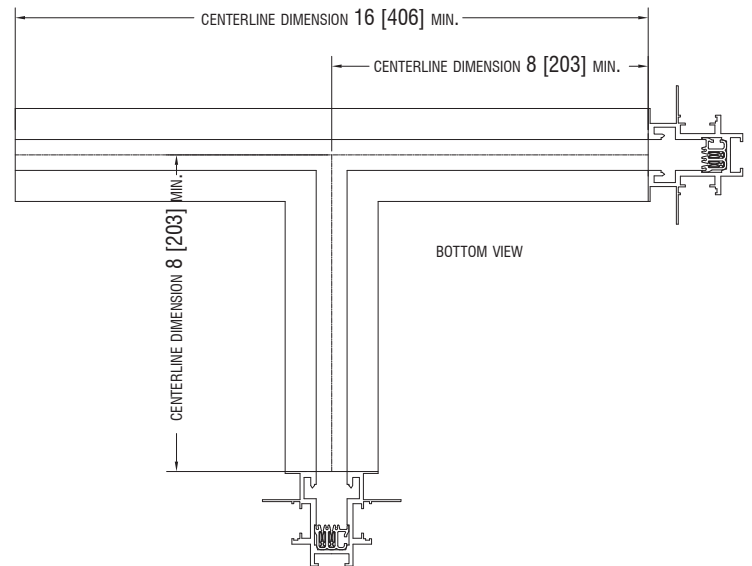

MAXIMUM UNIT LENGTH IS 10' [3048] UNINTERRUPTED SPAN. SPLICE KITS TO ADJACENT SECTIONS OCCUPY 4" [102] FOR 16, 20 AND 30 AMP CAPACITY AND 6" FOR 60 AMP CAPACITY. WHEN CALCULATING PLUG-IN SPACE:

$$(TOTAL LENGTH OF SECTION) - (FEED) - (SPLICE KIT/2) = TOTAL AVAILABLE PLUG-IN SPACE$$

FOR FITTER LENGTHS, PLEASE SEE FIXTURE CUTSHEETS.

BUS-14R

X, T, L Configurations

Project Name

Type

X-Dimensions (Typical):

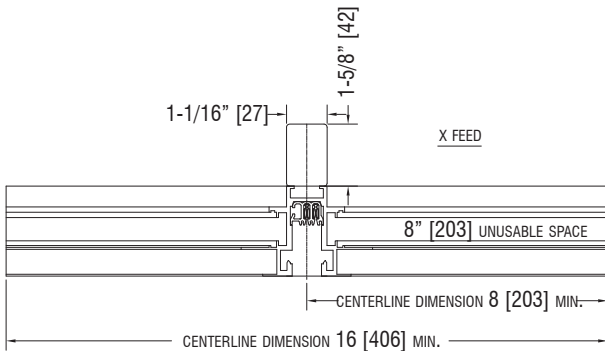
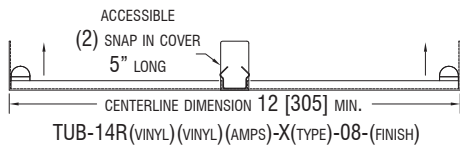
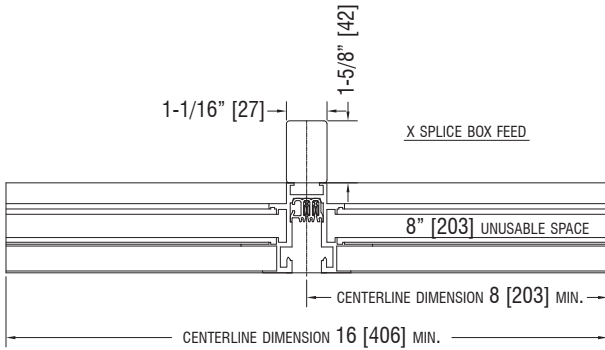

TUF-14R(VINYL)(VINYL)(AMPS)-X(TYPE)-08-(FINISH)

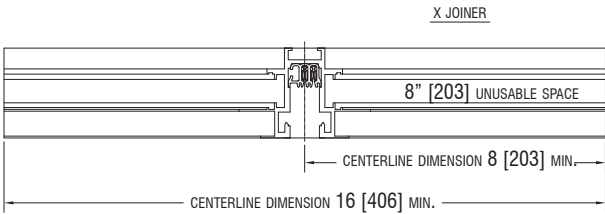

TUF-14R(VINYL)(VINYL)(AMPS)-X(TYPE)-08-(FINISH)

MAXIMUM UNIT LENGTH IS 10' [3048] UNINTERRUPTED SPAN. SPLICE KITS TO ADJACENT SECTIONS OCCUPY 4" [102] FOR 16, 20 AND 30 AMP CAPACITY AND 6" FOR 60 AMP CAPACITY. WHEN CALCULATING PLUG-IN SPACE:

$$(TOTAL LENGTH OF SECTION) - (FEED) - (SPLICE KIT/2) = TOTAL AVAILABLE PLUG-IN SPACE$$

FOR FITTER LENGTHS, PLEASE SEE FIXTURE CUTSHEETS.

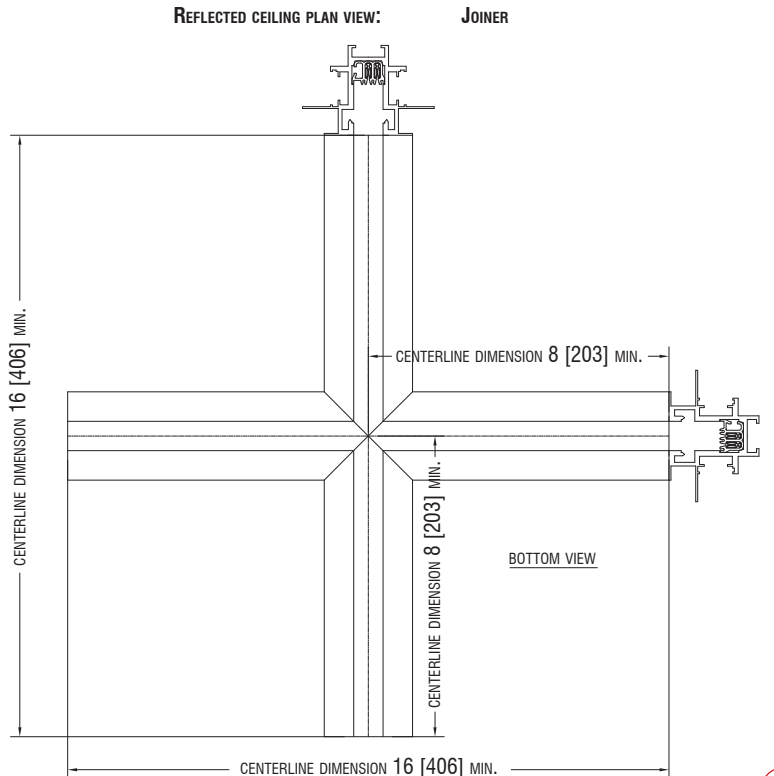
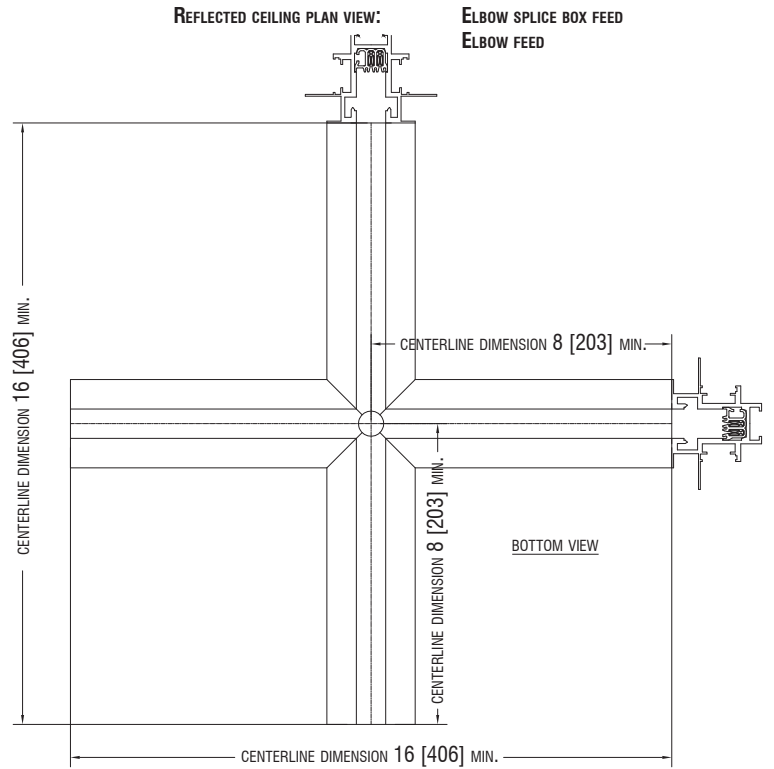

251 Elm Street, Buffalo, NY 14203 USA
800-238-4120 | www.litelab.com



BUS-14R

Accessories

Project Name

Type

BusBridge

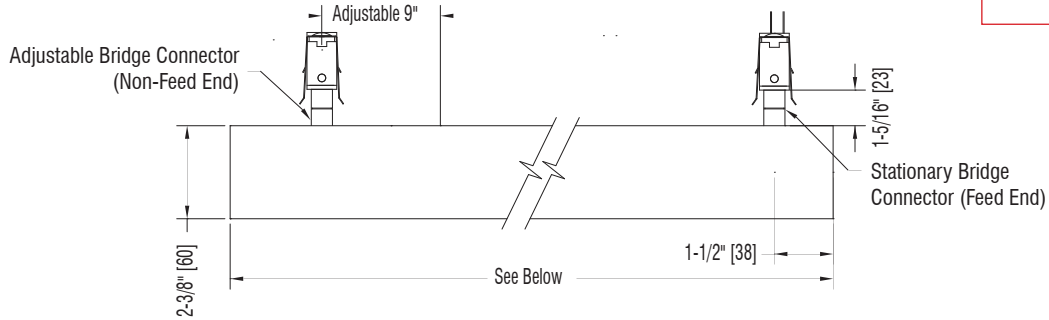

Maximum Load: 40 lbs

Codes	Adaptor/Voltage	Finish
BB1D-054 3'9" [Min. Span] 4'3" [Max. Span] 4'6" [Total Length]	9AD-A (120 Volts)	P=White
BB1D-102 7'9" [Min. Span] 8'3" [Max. Span] 8'6" [Total Length]	9AD-D (240 Volts)	MB = Matte Black
BB1D-120 9'0" [Min. Span] 9'9" [Max. Span] 10'0" [Total Length]	9AD-C (277 Volts)	NT = Brushed UF = Unfinished ST = Silver Tone

Example: BB1D-102-9AD-A-MB

Sign Hanger*

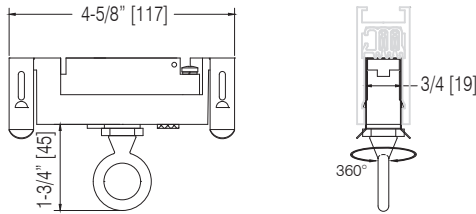

Supports 40lb (18kg) Maximum Static Vertical Load

Code	Adaptor	Finish
BSH	9ED	P=White MB = Matte Black ST = Silver Tone R = Unfinished

Loadmatic Hanging

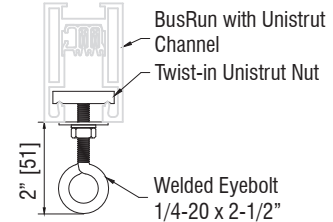

Supports up to 100lb [45kg] Maximum Static Vertical Load

Code	Finish
BSH-UNI	P=White MB = Matte Black R = Unfinished

PowerDown Box*

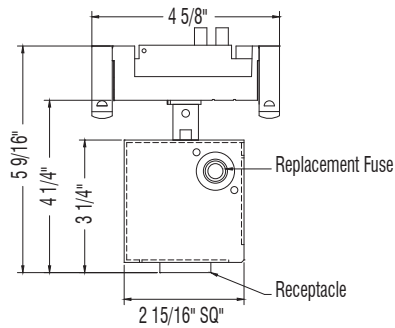

Code/Amperage	Adaptor / Voltage	Finish
3-Prong Edison Plug		P=White
BPT-P15F	9AD-A (120 Volts)	MB=Matte Black
Twist Lock		ST=Silver Tone
BPT-T15F	9AD-A (120 Volts)	CP=Custom Finish
BPT-T20F	9AD-C (277 Volts)	

NEMA Guide	120 volt	277 volt
BPT-P15F	5-15R	
BPT-T15F	L5-15R	L7-15R
BPT-T20F	L5-20R	L7-20R

PowerDown Breaker*

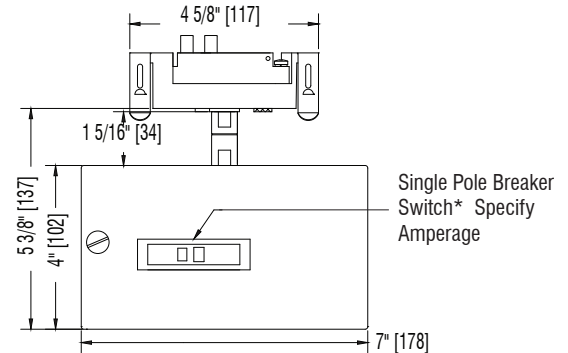

Code/Amperage	Adaptor / Voltage	Finish
BPT-K15B	9AD (120 Volts)	P=White
BPT-K20B		MB=Matte Black
BPT-K30B		ST=Silver Tone
		CP=Custom Finish

Includes knockouts

* Includes 11" Safety Cable



251 Elm Street, Buffalo, NY 14203 USA
800-238-4120 | www.litelab.com



06.10.2019