

BUS-11R

Recessed T-Bar, Trimmed



Project Name

Type

<input type="text"/>	<input type="text" value="-11R"/>	<input type="text"/>	<input type="text" value="XX"/>	<input type="text"/>	<input type="text"/>	<input type="text"/>	<input type="text"/>
----------------------	-----------------------------------	----------------------	---------------------------------	----------------------	----------------------	----------------------	----------------------

Feed Code	Profile / Mounting	Vinyl / Voltage	Vinyl / Voltage	Amperage	Total Length of Straight Run (in.)*	Finish	Whip (ft.)
BUS	CEC	1A	n/a	16A	1A	White	P
EEB	SEC	2A		20A	1.5A	Matte Black	MB
EEF	TEC	6A		30A	2A	Brushed	NT
SCB		3D		60A	3A	Unfinished	UF
SCF		2D			4A	Custom	CP
SEB		6D			5A		
SEF		3C			6A		
TCB		4B			8A		
TCF		4K			12A		
TEB							
TEF							

Circuiting Chart

1A 1 circ. (120V) 1-hot, 1-neutral 	2A 2 circ. (120V) 2-hot, 1-neutral 	3D 1 circ. (230V) 1-hot, 1-neutral
2D 2 circ. (240V) 2-hot, 1-neutral 	3C 1 circ. (277V) 1-hot, 1-neutral 	4B (Consult Factory) 1 circ. (Low Voltage) 1-hot, 1-neutral
4K (Consult Factory) 1 circ. (Low Voltage) International 1-hot, 1-neutral 	6A 1 circ. (120V) 2-hot, 1-neutral tied hots 	6D 1 circ. (230V) 2-hot, 1-neutral tied hots

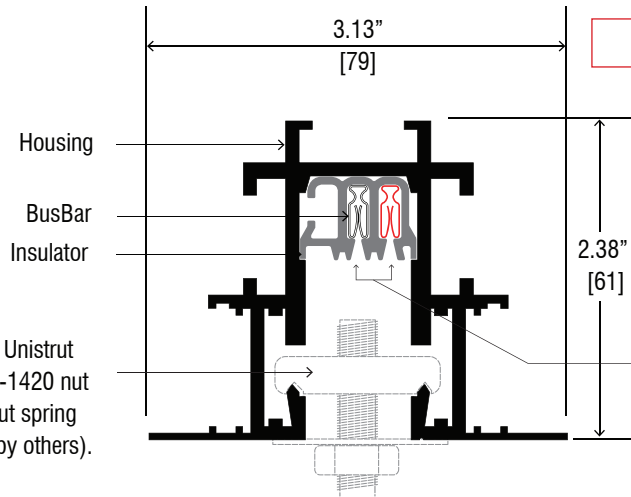

Accepts Unistrut #P-3006-1420 nut without spring (by others).

Shown is one circuit BusRun. Refer to chart below for circuiting options.

Feed Options: Standard BusRun feed capacity is 20 Amps (120v) or 16 Amps (230 Volt); 30 and 60 Amp feeds are available

TEF-11R
TEC-11R ((Current Limiter)*)
 Top End Feed
 1/2" NPSM or 20mm Conduit

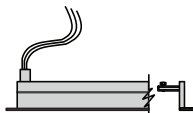

TCF-11R
 Top Center Feed
 1/2" NPSM or 20mm Conduit

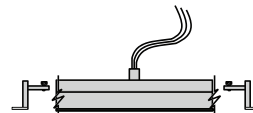

SEF-11R
SEC-11R (Current Limiter)*)
 Side End Feed
 1/2" NPSM or 20mm Conduit

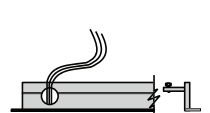

TEB-11R
 Top End Splice-Box
 30 Amp Max

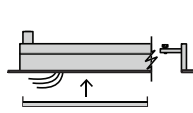

TCB-11R
 Top Center Splice Box
 30 Amp Max

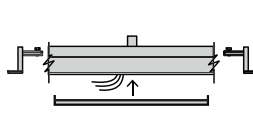

SEB-11R
 Side End Splice Box
 30 Amp Max

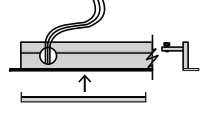

EEF-11R
EEC-11R ((Current Limiter)*)
 End End Feed
 1/2" NPSM or 20mm Conduit

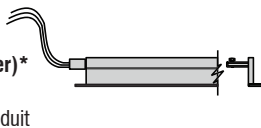

EEB-11R
 End End Splice-Box
 30 Amp Max

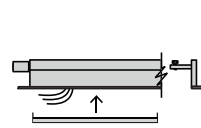

SCF-11R
 Side Center Feed
 1/2" NPSM or 20mm Conduit

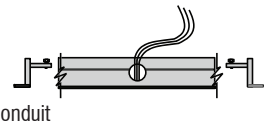

Notes:

1. All Splice Box feeds are 30 Amp maximum load.
2. All feeds are supplied with two end caps.
3. Feeds cannot be field modified.
4. Feeds can be made between 10" - 120".
5. Maximum loads are per circuit.

*CL: Current Limiter Values (120v Only)			
1A	120VA	5A	600VA
1.5A	180VA	6A	720VA
2A	240VA	8A	960VA
3A	360VA	12A	1440VA
4A	480VA		

SCB-11R

Side Center Splice Box
 30 Amp Max

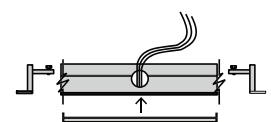

BUS-11R

Recessed T-Bar, Trimmed

Project Name

Type

Dimension Chart

Top End Feed

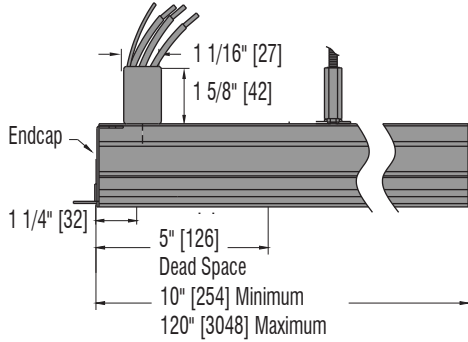

Top End Splice-Box Feed

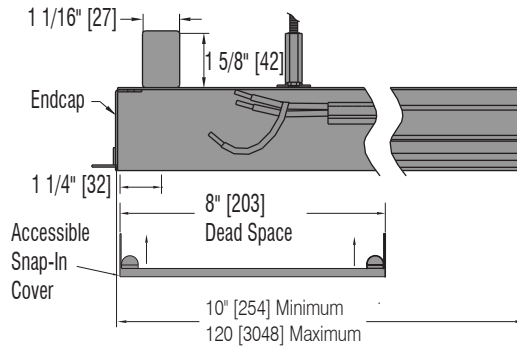

End End Feed

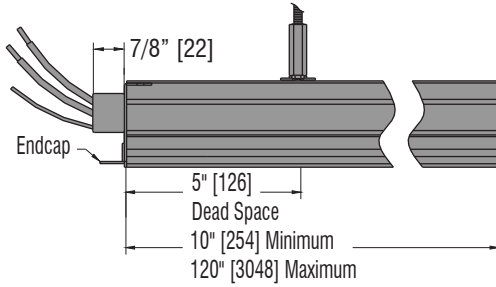

End End Splice-Box Feed

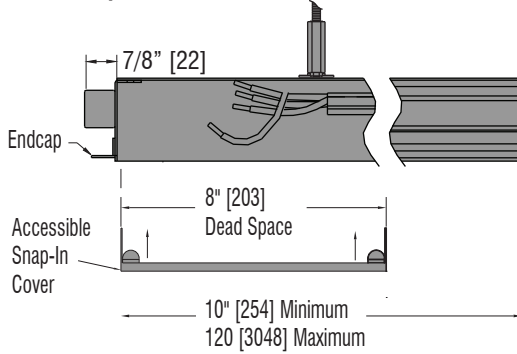

Side End Feed

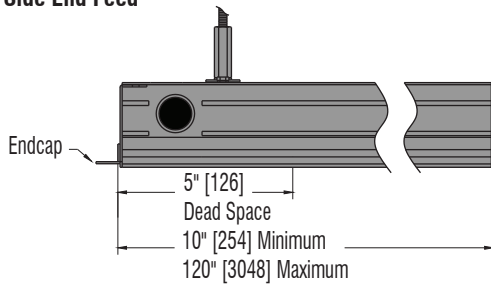

Side End Splice-Box Feed

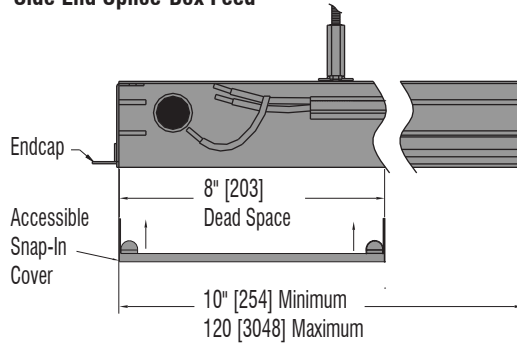

Top Center Feed

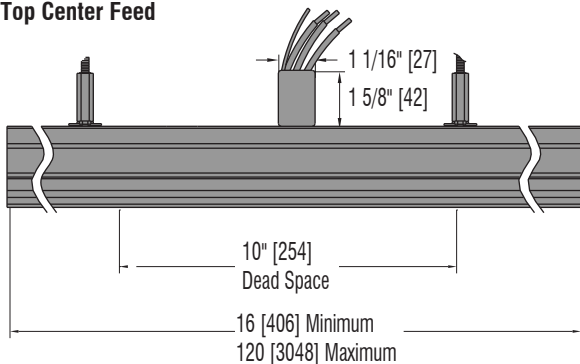

Top Center Splice-Box Feed

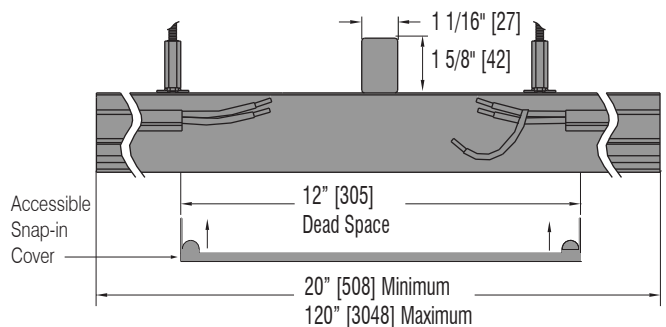

BUS-11R

Recessed T-Bar, Trimmed

Project Name

Type

Mounting Diagram

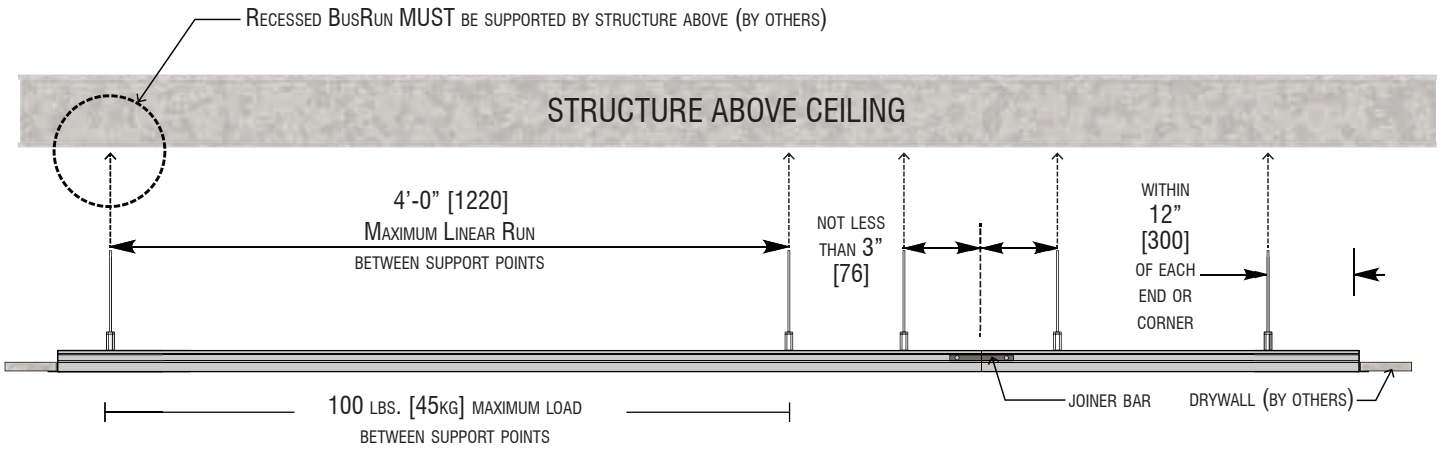

MOUNTING NOTES:

- 10'0" [3048] RECESSED BUSRUN SECTION REQUIRES 3 SUPPORT POINTS.
- 8'0" [2438] RECESSED BUSRUN SECTION REQUIRES 3 SUPPORT POINTS.
- 4'0" [1219] RECESSED BUSRUN SECTION REQUIRES 2 SUPPORT POINTS.

MOUNTING RULES

- 12" [300]** A SUPPORT POINT MUST BE PROVIDED WITHIN 12" OF EVERY END CORNER OF THE BUSRUN LAYOUT.
- 4'-0" [1220]** MAXIMUM DISTANCE BETWEEN SUPPORT POINTS CANNOT EXCEED 4'0" LINEAR FEET OF BUSRUN.
- 3" [76]** SUPPORT POINTS CANNOT BE WITHIN 3" FROM THE CENTERLINE ON BOTH SIDES OF BUSRUN JOINTS.
- 100LB [45KG]** BUSRUN BUSWAY AND MOUNTING HARDWARE ARE RATED FOR A TOTAL SUPPORTED WEIGHT UP TO 100 LBS [45KG] BETWEEN SUPPORT POINTS.

MOUNTING OPTIONS

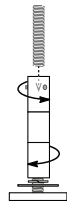

THREADED ROD HANGER

NICKEL-PLATED COUNTER-ROTATING THREADED ROD HANGER AND MOUNTING BAR ENABLE ATTACHMENT AND LEVELING OF BUSRUN TO FIXED THREADED ROD.

- B-HHO-TR250 FOR 1/4-20 ROD
- B-HHO-TR375 FOR 3/8-16 ROD

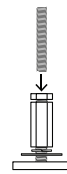

COUPLING NUT FOR THREADED ROD

- B-HHO-CK-M6-01 FOR M6 ROD



RETAINING CLIP FOR CEILING SYSTEM

- TBC-IT-01 (ORDERED SEPARATELY)

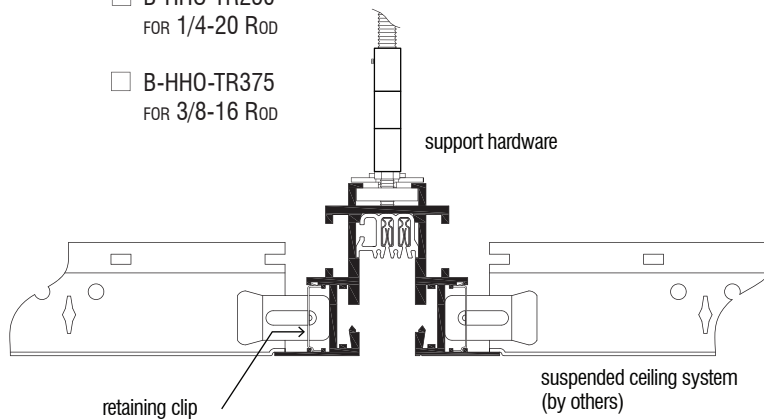

BUS-11R

X, T, L Configurations

Project Name

Type

L-Dimensions (Typical):

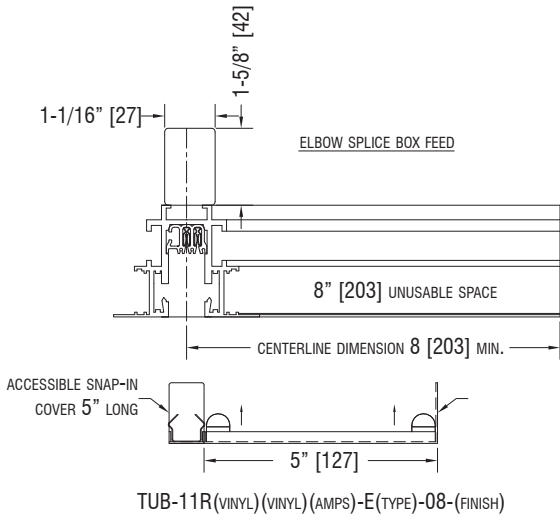

REFLECTED CEILING PLAN VIEW:

ELBOW SPLICE BOX FEED
ELBOW FEED

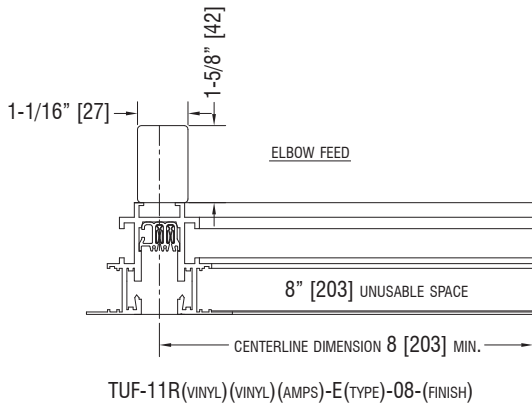
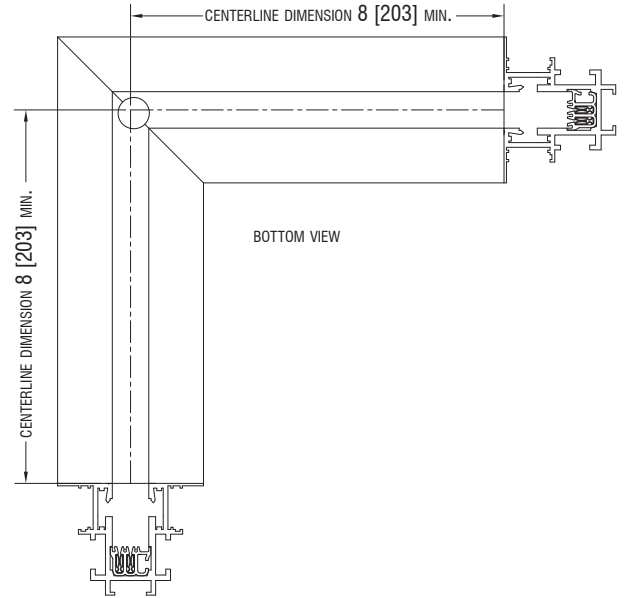

REFLECTED CEILING PLAN VIEW:

JOINER

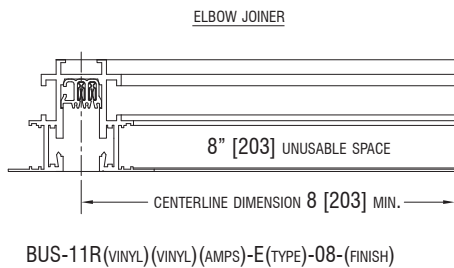
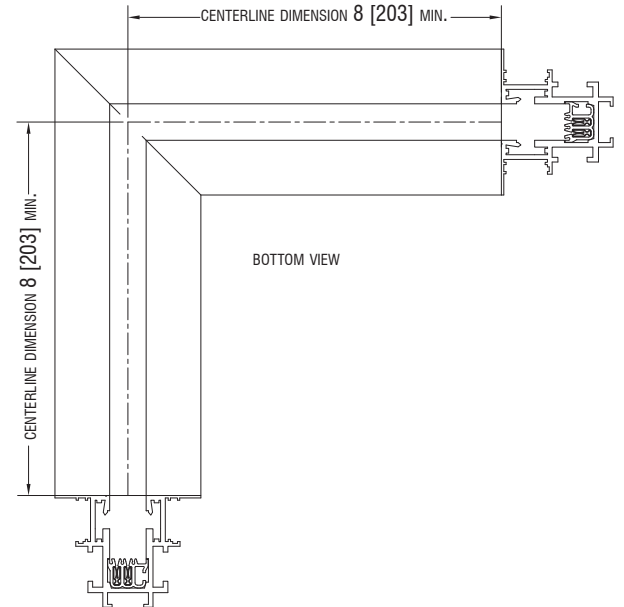

MAXIMUM UNIT LENGTH IS 10' [3048] UNINTERRUPTED SPAN. SPLICE KITS TO ADJACENT SECTIONS OCCUPY 4" [102] FOR 16, 20 AND 30 AMP CAPACITY AND 6" FOR 60 AMP CAPACITY. WHEN CALCULATING PLUG-IN SPACE:

$$(TOTAL LENGTH OF SECTION) - (FEED) - (SPLICE KIT/2) = TOTAL AVAILABLE PLUG-IN SPACE$$

FOR FITTER LENGTHS, PLEASE SEE FIXTURE CUTSHEETS.

BUS-11R

X, T, L Configurations

Project Name

Type

T-Dimensions (Typical):

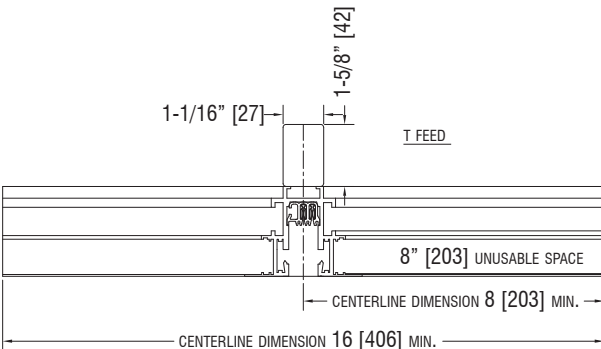
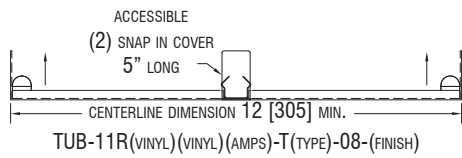
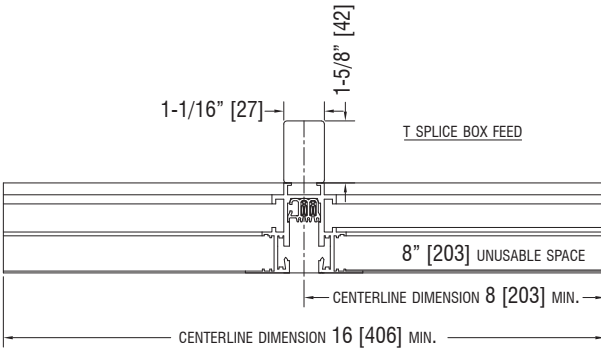

TUF-11R(VINYL)(VINYL)(AMPS)-T(TYPE)-08-(FINISH)

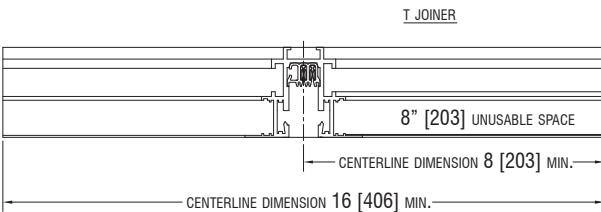

TUF-11R(VINYL)(VINYL)(AMPS)-T(TYPE)-08-(FINISH)

MAXIMUM UNIT LENGTH IS 10' [3048] UNINTERRUPTED SPAN. SPLICE KITS TO ADJACENT SECTIONS OCCUPY 4" [102] FOR 16, 20 AND 30 AMP CAPACITY AND 6" FOR 60 AMP CAPACITY. WHEN CALCULATING PLUG-IN SPACE:

$$(TOTAL LENGTH OF SECTION) - (FEED) - (SPLICE KIT/2) = TOTAL AVAILABLE PLUG-IN SPACE$$

FOR FITTER LENGTHS, PLEASE SEE FIXTURE CUTSHEETS.

REFLECTED CEILING PLAN VIEW:

ELBOW SPLICE BOX FEED
ELBOW FEED

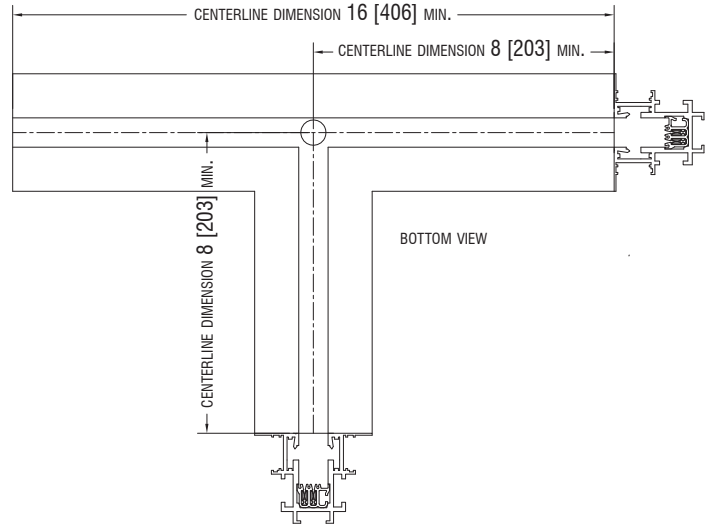

REFLECTED CEILING PLAN VIEW:

JOINER

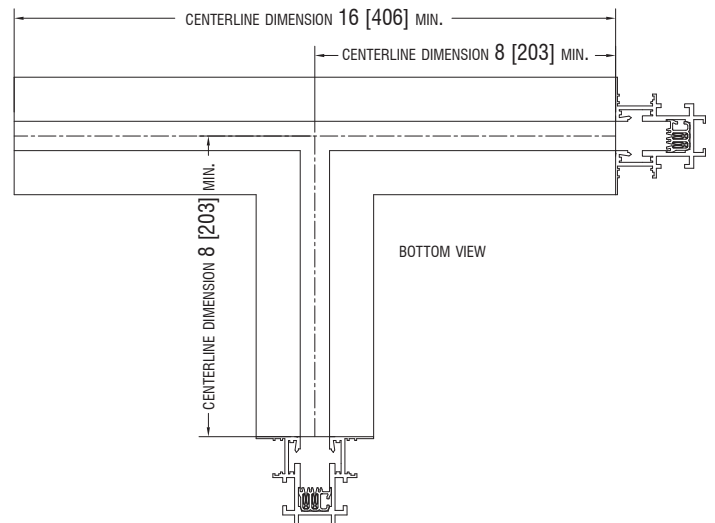

BUS-11R

X, T, L Configurations

Project Name

Type

X-Dimensions (Typical):

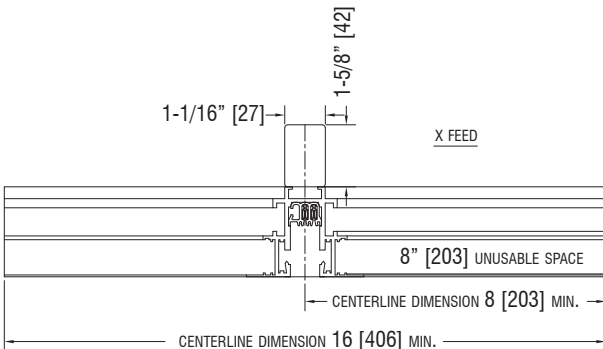
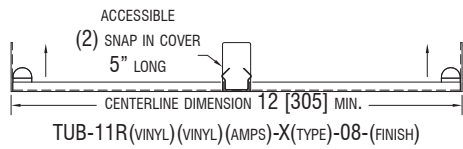
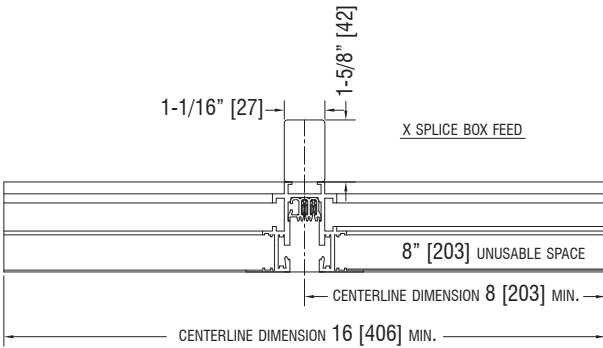

TUF-11R(VINYL)(VINYL)(AMPS)-X(TYPE)-08-(FINISH)

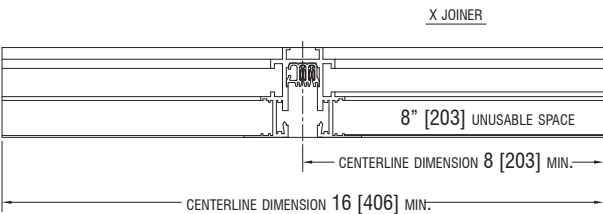

TUF-11R(VINYL)(VINYL)(AMPS)-X(TYPE)-08-(FINISH)

MAXIMUM UNIT LENGTH IS 10' [3048] UNINTERRUPTED SPAN. SPLICE KITS TO ADJACENT SECTIONS OCCUPY 4" [102] FOR 16, 20 AND 30 AMP CAPACITY AND 6" FOR 60 AMP CAPACITY. WHEN CALCULATING PLUG-IN SPACE:

$$(TOTAL LENGTH OF SECTION) - (FEED) - (SPLICE KIT/2) = TOTAL AVAILABLE PLUG-IN SPACE$$

FOR FITTER LENGTHS, PLEASE SEE FIXTURE CUTSHEETS.

REFLECTED CEILING PLAN VIEW:

ELBOW SPLICE BOX FEED
ELBOW FEED

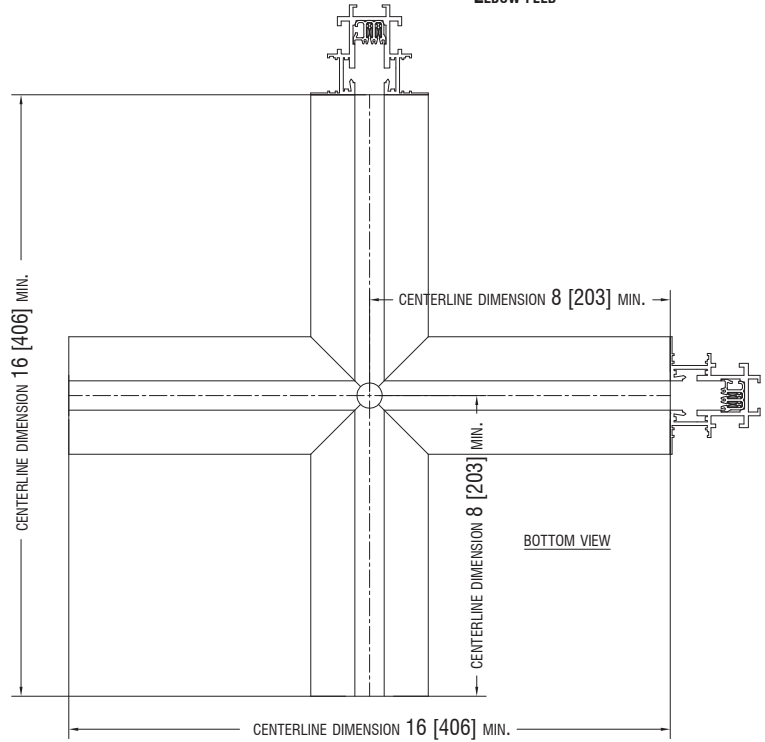

REFLECTED CEILING PLAN VIEW:

JOINER

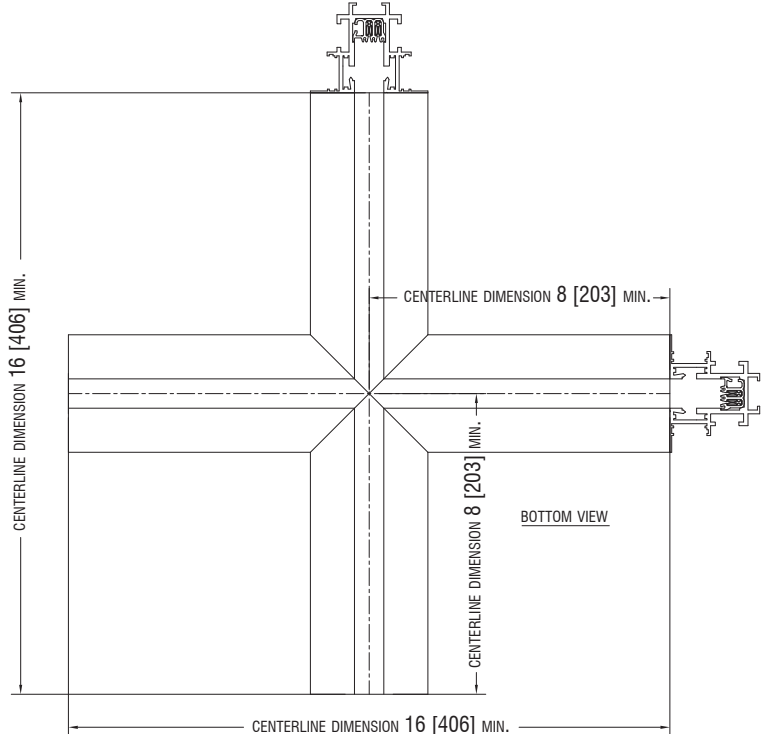

BUS-11R

Accessories

Project Name

Type

BusBridge

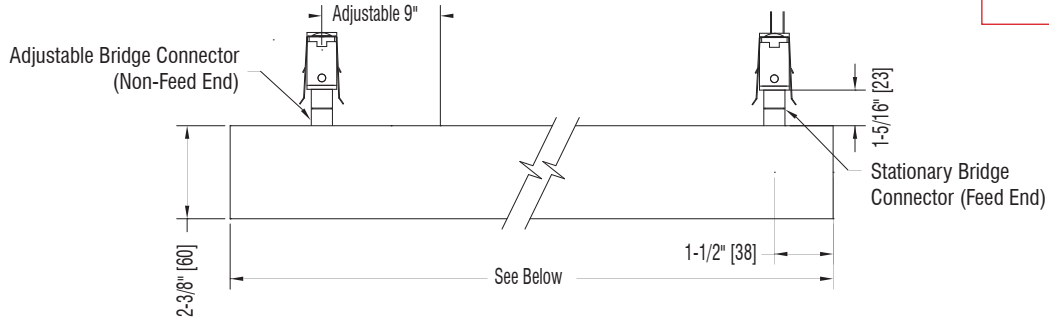

Maximum Load: 40 lbs

Codes	Adaptor/Voltage	Finish
BB1D-054 3'9" [Min. Span] 4'3" [Max. Span] 4'6" [Total Length]	9AD-A (120 Volts)	P=White
BB1D-102 7'9" [Min. Span] 8'3" [Max. Span] 8'6" [Total Length]	9AD-D (240 Volts)	MB = Matte Black
BB1D-120 9'0" [Min. Span] 9'9" [Max. Span] 10'0" [Total Length]	9AD-C (277 Volts)	NT = Brushed
		UF = Unfinished
		ST = Silver Tone

Example: BB1D-102-9AD-A-MB

Sign Hanger*

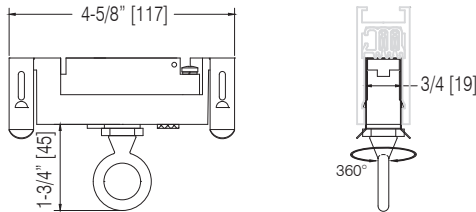

Supports 40lb (18kg) Maximum Static Vertical Load

Code	Adaptor	Finish
BSH	9ED	P=White
		MB = Matte Black
		ST = Silver Tone
		R = Unfinished

Loadmatic Hanging

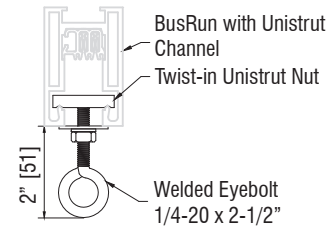

Supports up to 100lb [45kg] Maximum Static Vertical Load

Code	Finish
BSH-UNI	P=White
	MB = Matte Black
	R = Unfinished

PowerDown Box*

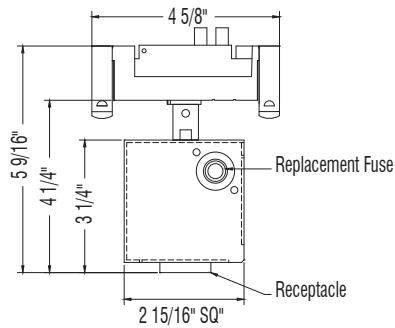

Code/Amperage	Adaptor / Voltage	Finish
3-Prong Edison Plug		P=White
BPT-P15F	9AD-A (120 Volts)	MB=Matte Black
Twist Lock		ST=Silver Tone
BPT-T15F	9AD-A (120 Volts)	CP=Custom Finish
BPT-T20F		

NEMA Guide	120 volt	277 volt
BPT-P15F	5-15R	
BPT-T15F	L5-15R	L7-15R
BPT-T20F	L5-20R	L7-20R

PowerDown Breaker*

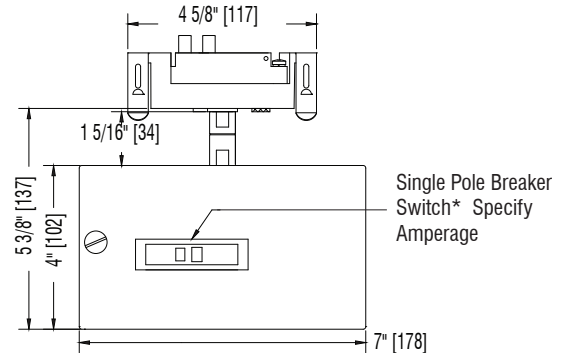

Code/Amperage	Adaptor / Voltage	Finish
BPT-K15B	9AD (120 Volts)	P=White
BPT-K20B		MB=Matte Black
BPT-K30B		ST=Silver Tone
		CP=Custom Finish

Includes knockouts

* Includes 11" Safety Cable



251 Elm Street, Buffalo, NY 14203 USA
800-238-4120 | www.litelab.com

