

# BUS-09S

Surface-Mounted



Project Name

Type

Project Name:

Type:

Code:  -09S

Feed Code	Profile / Mounting	Vinyl / Voltage	Vinyl / Voltage	Amperage	Total Length of Straight Run (in.)*	Finish	Whip (ft.)
BUS	CEC	1A	1A	16A	1A	White	P
CCF	EEC	2A	2A	20A	1.5A	Matte Black	MB
CEF	SEC	6A	6A	30A	2A	Brushed	NT
EEB	TEC	3D	3D	60A	3A	Unfinished	UF
EEF		2D	2D		4A	Custom	CP
SEF		6D	6D		5A		
TCB		3C	3C		6A		
TCF		4B	4B		8A		
TEB		4K	4K		12A		
TEF							

Finish Code:

## Circuiting Chart

<b>1A</b> 1 circ. (120V) 1-hot, 1-neutral 	<b>2A</b> 2 circ. (120V) 2-hot, 1-neutral 	<b>3D</b> 1 circ. (230V) 1-hot, 1-neutral 
<b>2D</b> 2 circ. (240V) 2-hot, 1-neutral 	<b>3C</b> 1 circ. (277V) 1-hot, 1-neutral 	<b>4B (Consult Factory)</b> 1 circ. (Low Voltage) 1-hot, 1-neutral 
<b>4K (Consult Factory)</b> 1 circ. (Low Voltage) International 1-hot, 1-neutral 	<b>6A</b> 1 circ. (120V) 2-hot, 1-neutral tied hots 	<b>6D</b> 1 circ. (230V) 2-hot, 1-neutral tied hots 

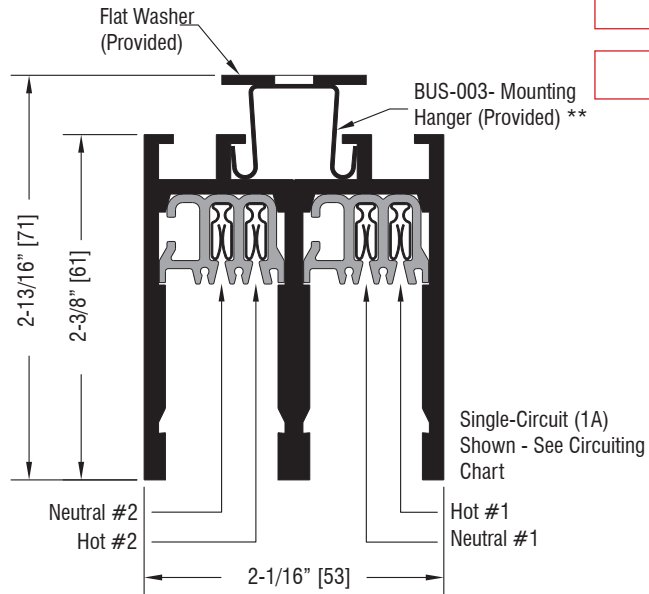

**Feed Options:** Standard BusRun feed capacity is 20 Amps (120v) or 16 Amps (230 Volt); 30 and 60 Amp feeds are available

**CEF-09S**  
**CEC (Current Limiter)\***  
 Canopy End Feed  
 (6-3/4" Round Canopy)

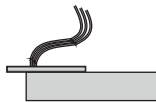

**CCF-09S**  
 Canopy Center Feed  
 (6-3/4" Round Canopy)

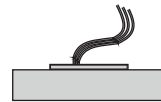

**SEF-09S**  
**SEC-09S (Current Limiter)\***  
 Side End Feed  
 1/2" NPSM or 20mm Conduit



**TEF-09S**  
**TEC-09S ((Current Limiter)\***  
 Top End Feed  
 1/2" NPSM or 20mm Conduit

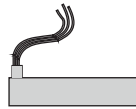

**TCF-09S**  
 Top Center Feed  
 1/2" NPSM or 20mm Conduit

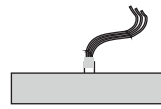

**EEF-09S**  
**EEC-09S (Current Limiter)\***  
 End End Feed  
 1/2" NPSM or 20mm Conduit



**TEB-09S**  
 Top End Splice-Box  
 30 Amp Max

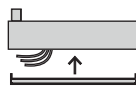

**TCB-09S**  
 Top Center Splice Box  
 30 Amp Max

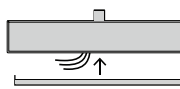

**EEB-09S**  
 End End Splice-Box  
 30 Amp Max

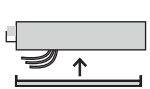

\* For L, T and X Configurations, visit Page 3.

\*\* BUS-003 consists of (3) mounting clips.  
**Order Code for Mounting Clips is B-HS3**, which comprises (4) packs of BUS-003, or (12) Clips.

*CL: Current Limiter Values (120v Only)			
1A	120VA	5A	600VA
1.5A	180VA	6A	720VA
2A	240VA	8A	960VA
3A	360VA	12A	1440VA
4A	480VA		

# BUS-09S

Surface-Mounted

Project Name

Type

## Mounting Diagram

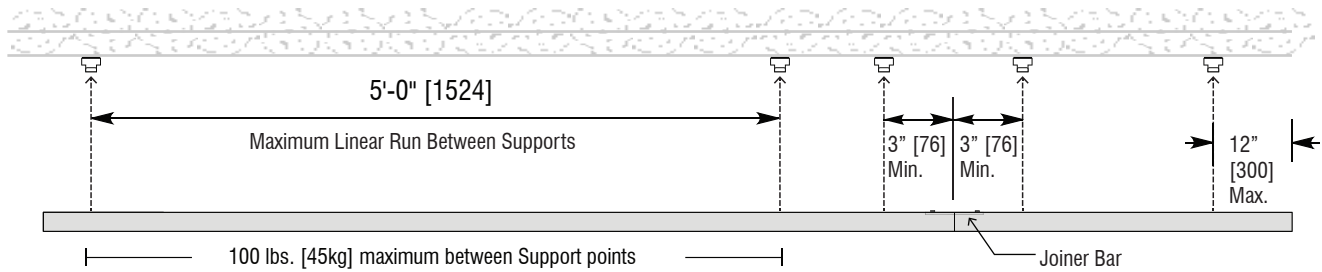

## Dimension Chart

### Top End Feed

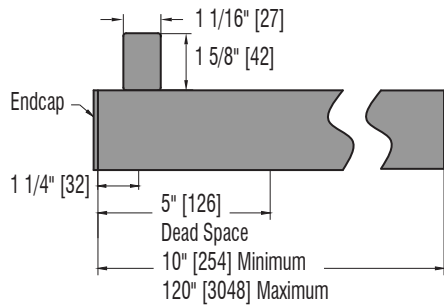

### Top End Splice-Box Feed

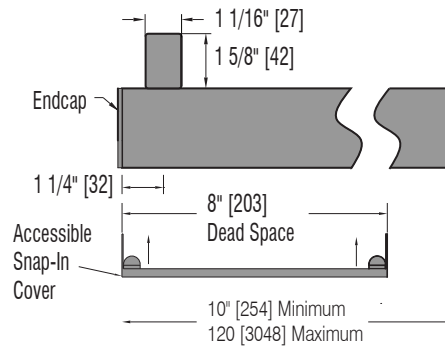

### End End Feed

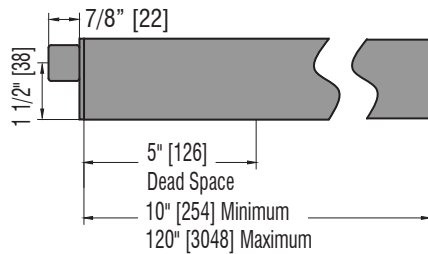

### End End Splice-Box Feed

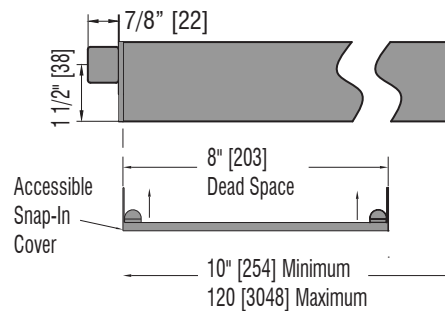

### Top Center Feed

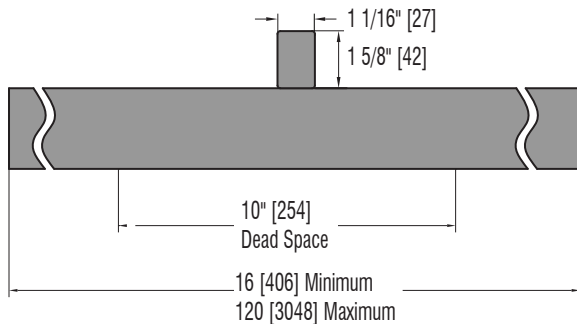

### Top Center Splice-Box Feed

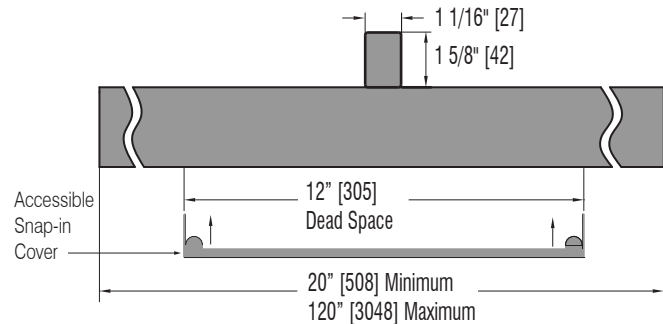

# BUS-09S

X, T, L Configurations

Project Name

Type



## L-Dimensions (Typical):

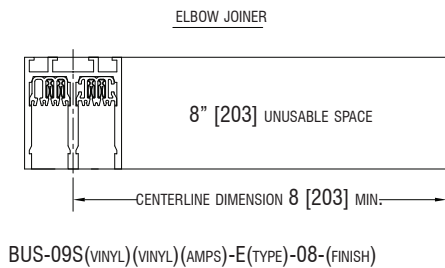
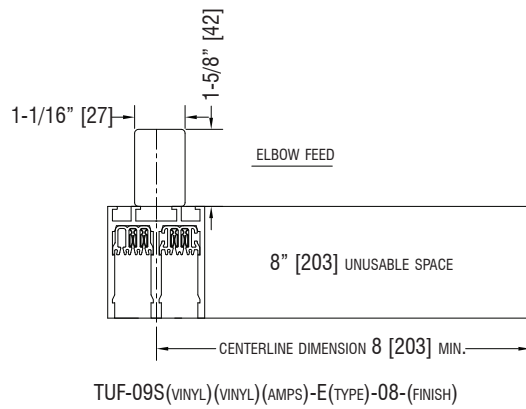
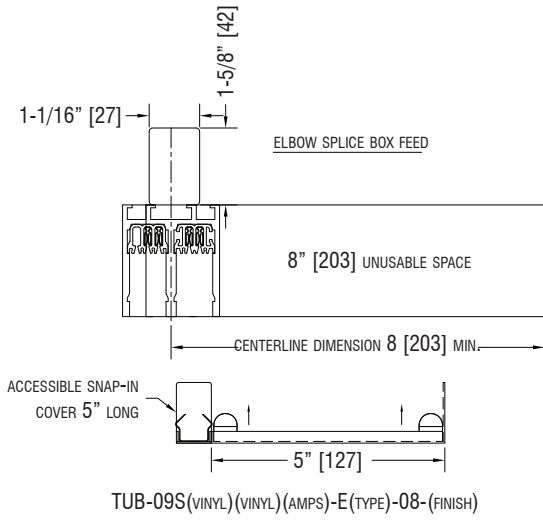

MAXIMUM UNIT LENGTH IS 10' [3048] UNINTERRUPTED SPAN. SPLICE KITS TO ADJACENT SECTIONS OCCUPY 4" [102] FOR 16, 20 AND 30 AMP CAPACITY AND 6" FOR 60 AMP CAPACITY. WHEN CALCULATING PLUG-IN SPACE:

$$(TOTAL LENGTH OF SECTION) - (FEED) - (SPLICE KIT/2) = TOTAL AVAILABLE PLUG-IN SPACE$$

FOR FITTER LENGTHS, PLEASE SEE FIXTURE CUTSHEETS.

REFLECTED CEILING PLAN VIEW:

ELBOW SPLICE BOX FEED  
ELBOW FEED

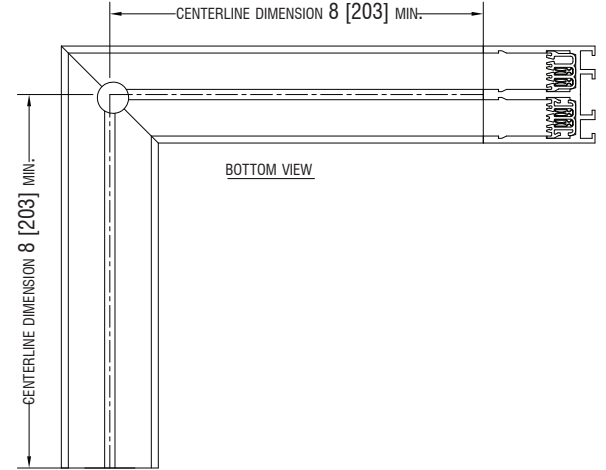

REFLECTED CEILING PLAN VIEW:

JOINER

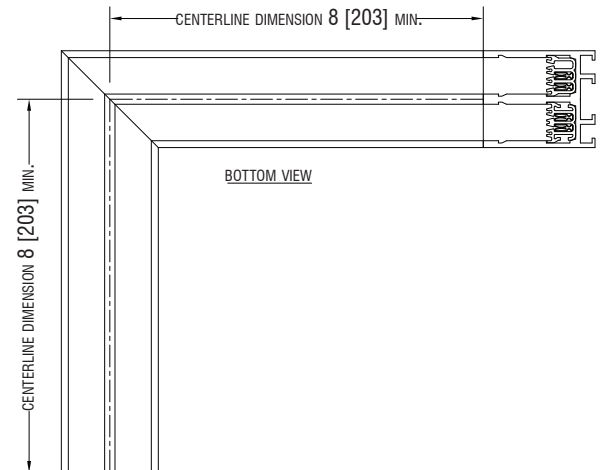

# BUS-09S

X, T, L Configurations

Project Name

Type



## T-Dimensions (Typical):

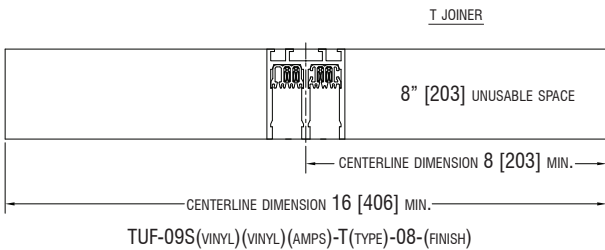
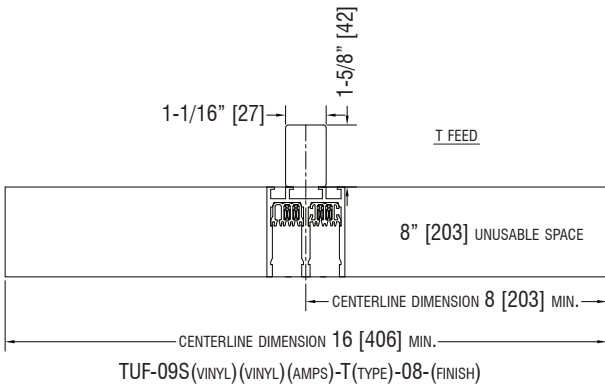
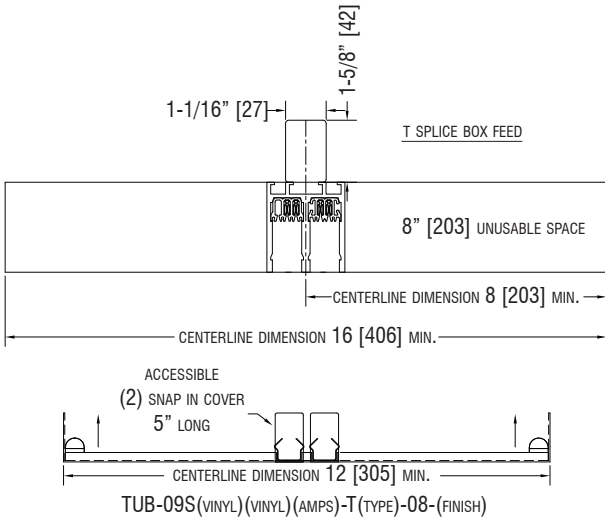

MAXIMUM UNIT LENGTH IS 10' [3048] UNINTERRUPTED SPAN. SPLICE KITS TO ADJACENT SECTIONS OCCUPY 4" [102] FOR 16, 20 AND 30 AMP CAPACITY AND 6" FOR 60 AMP CAPACITY. WHEN CALCULATING PLUG-IN SPACE:

$$(TOTAL LENGTH OF SECTION) - (FEED) - (SPLICE KIT/2) = TOTAL AVAILABLE PLUG-IN SPACE$$

FOR FITTER LENGTHS, PLEASE SEE FIXTURE CUTSHEETS.

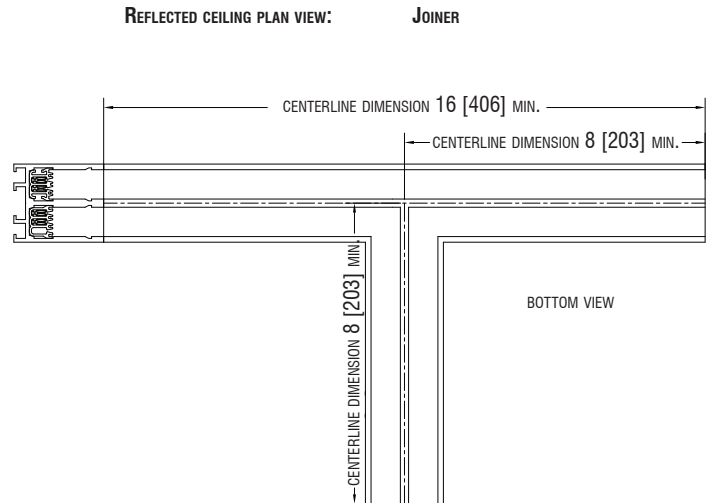
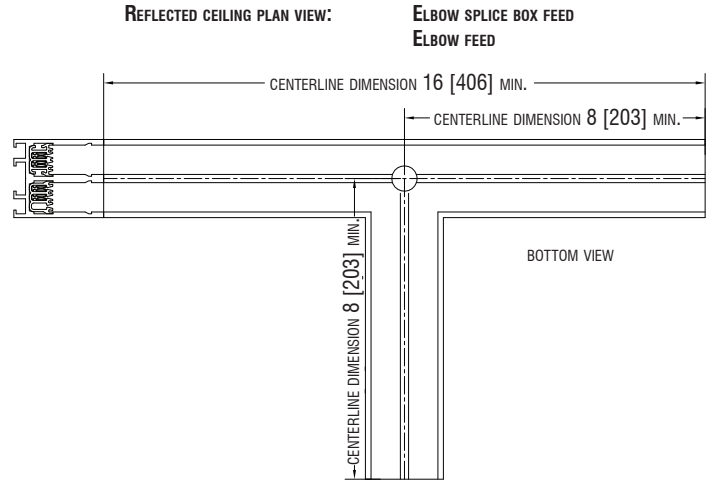

# BUS-09S

X, T, L Configurations

Project Name

Type



## X-Dimensions (Typical):

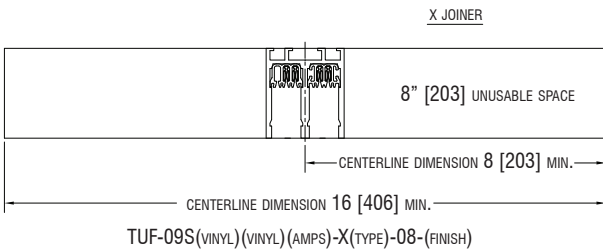
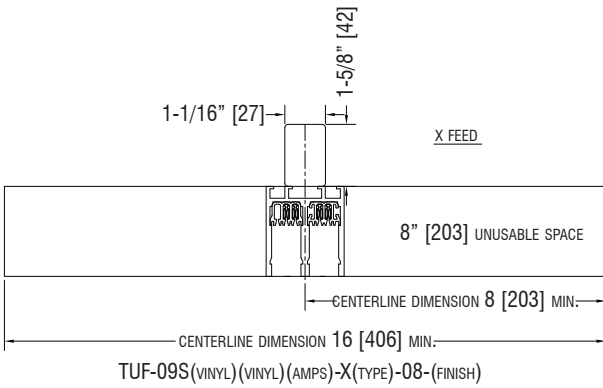
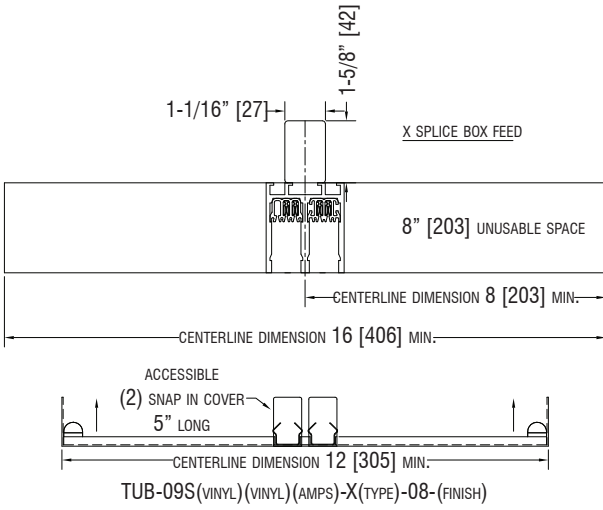

MAXIMUM UNIT LENGTH IS 10' [3048] UNINTERRUPTED SPAN. SPLICE KITS TO ADJACENT SECTIONS OCCUPY 4" [102] FOR 16, 20 AND 30 AMP CAPACITY AND 6" FOR 60 AMP CAPACITY. WHEN CALCULATING PLUG-IN SPACE:

$$(TOTAL LENGTH OF SECTION) - (FEED) - (SPLICE KIT/2) = TOTAL AVAILABLE PLUG-IN SPACE$$

FOR FITTER LENGTHS, PLEASE SEE FIXTURE CUTSHEETS.

REFLECTED CEILING PLAN VIEW:

ELBOW SPLICE BOX FEED  
ELBOW FEED

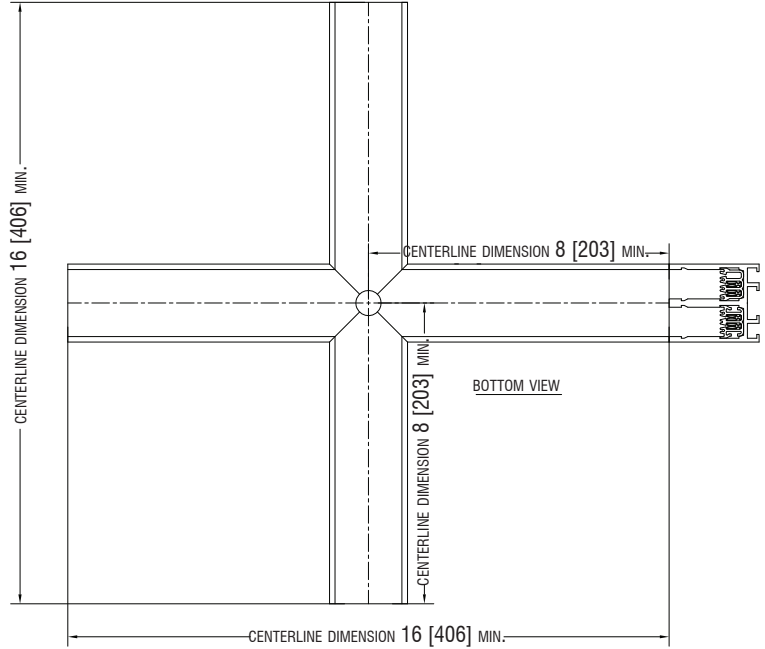

REFLECTED CEILING PLAN VIEW:

JOINER

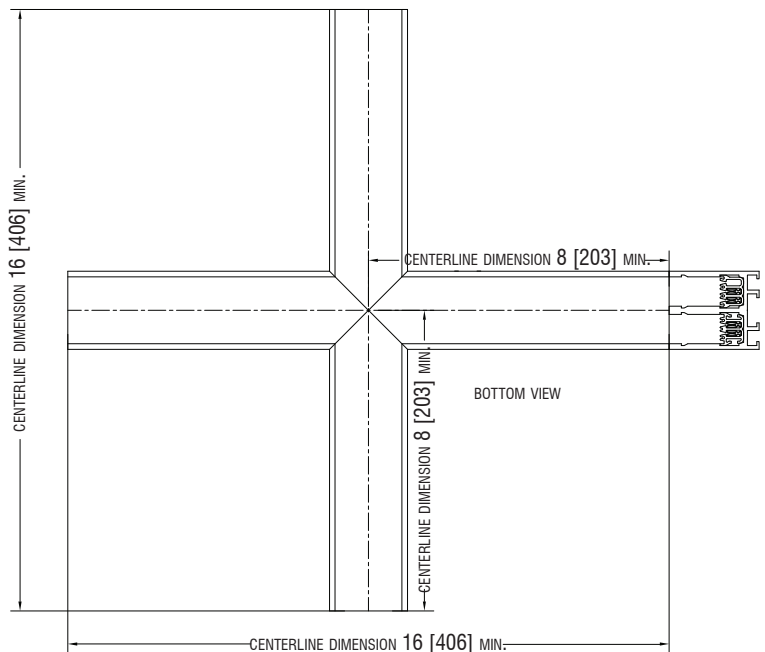

# BUS-09S

Accessories

Project Name

Type

## BusBridge

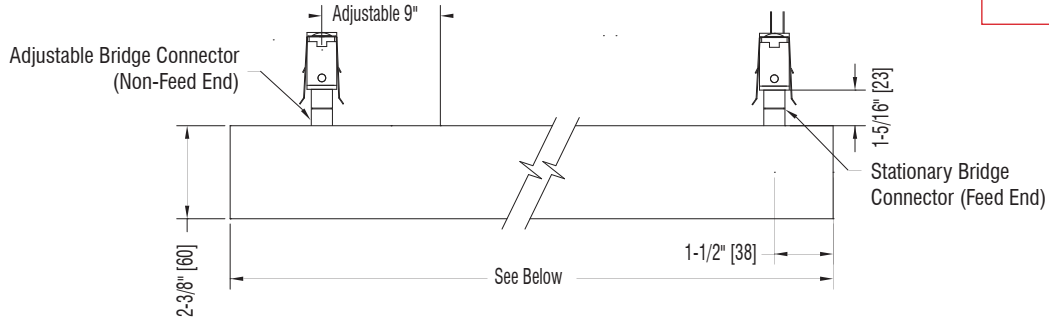

Maximum Load: 40 lbs

Codes	Adaptor/Voltage	Finish
BB1D-054 3'9" [Min. Span]   4'3" [Max. Span]   4'6" [Total Length]	9AD-A (120 Volts)	P=White
BB1D-102 7'9" [Min. Span]   8'3" [Max. Span]   8'6" [Total Length]	9AD-D (240 Volts)	MB = Matte Black
BB1D-120 9'0" [Min. Span]   9'9" [Max. Span]   10'0" [Total Length]	9AD-C (277 Volts)	NT = Brushed UF = Unfinished ST = Silver Tone

Example: BB1D-102-9AD-A-MB

## Sign Hanger\*

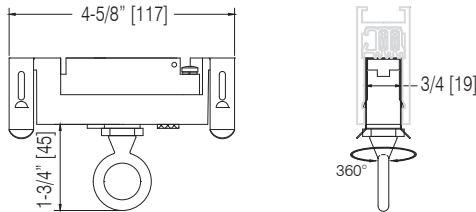

Supports 40lb (18kg) Maximum Static Vertical Load

Code	Adaptor	Finish
BSH	9ED	P=White MB = Matte Black ST = Silver Tone R = Unfinished

## Loadmatic Hanging

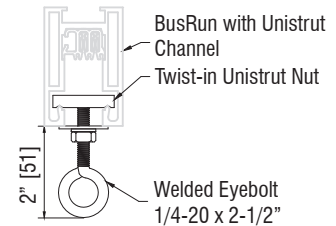

Supports up to 100lb [45kg] Maximum Static Vertical Load

Code	Finish
BSH-UNI	P=White MB = Matte Black R = Unfinished

## PowerDown Box\*

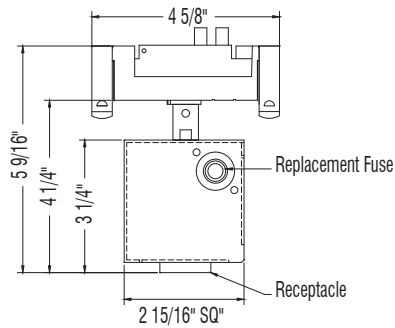

Code/Amperage	Adaptor / Voltage	Finish
3-Prong Edison Plug		P=White
BPT-P15F	9AD-A (120 Volts)	MB=Matte Black
Twist Lock		ST=Silver Tone
BPT-T15F	9AD-A (120 Volts)	CP=Custom Finish
BPT-T20F		

NEMA Guide	120 volt	277 volt
BPT-P15F	5-15R	
BPT-T15F	L5-15R	L7-15R
BPT-T20F	L5-20R	L7-20R

## PowerDown Breaker\*

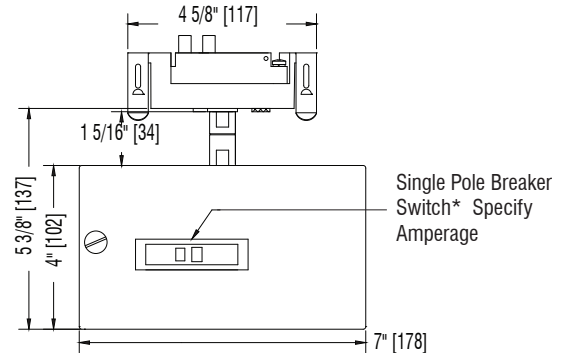

Code/Amperage	Adaptor / Voltage	Finish
BPT-K15B	9AD (120 Volts)	P=White
BPT-K20B		MB=Matte Black
BPT-K30B		ST=Silver Tone
		CP=Custom Finish

Includes knockouts

\* Includes 11" Safety Cable



251 Elm Street, Buffalo, NY 14203 USA  
800-238-4120 | www.litelab.com

